

North American **Clean Energy**

www.nacleanenergy.com

**Blockchain and
the Future of Energy**

**Just the
Tracks Ma'am**

**The Grey
Behind the Green**

USDA REAP Loans

Plus Show-in-Print Feature:

- Intersolar North America

Pg. 13



Pg. 54



• **OMCO SOLAR**

Introducing the
Field-Fast Racking system.
SEE OUR AD ON PAGE 7



imagine...

- NO combiner boxes
- NO field o&m
- NO torquing
- NO cable trays
- NO trenches
- NO re-combiners
- NO custom power stations

bla
big lead assembly™

Combining the function of:

- ✓ cable assembly
- ✓ combiner box
- ✓ external fuses
- ✓ re-combiner

The BLA (Big Lead Assembly ®) takes all the guesswork out of wiring your solar field. Using Shoals' latest in-line fuse and wire manufacturing technology, we offer you a site free of DC string combiners. The entire load is combined into a single pair of aluminum conductors running from the string combiner to the inverter. There's no need to trench for DC feeders or hang string combiner boxes. And when terminated with the BAC connector, the whole array is plug-&-play. Plug in the panel strings, plug into the inverter, and just walk away!



shoals®
technologies group

A top runner in China's smart energy evolution

--The only inverter company to receive direct investment from Sequoia Capital in China

Exploring more partnerships

Expanding the number of trusted partners, distributors, agents

Discovering more intelligent PV solutions

Local team in USA, Local warehouse in LA, California.

 **(818)800-9177**

We offer a complete range of solar inverters from 1-40kw, all UL1741SA certified and DNV tested:

- > 1-phase with dual MPPT from 1-10kw
- > 3-phase with dual MPPT from 10-40kw
- > Proven track record of reliability
- > Over 8.5G installation worldwide
- > Local team in the US, with warehouse in Los Angeles.
- > We offer local service and technical support in 20 countries, covering US, Europe, Australia and Asia.



Follow our homepage



Follow our Facebook



Growatt USA Inc.

A: 19201 Parthenia St., Suite E, Northridge, CA 91324

T: (818)800-9177 E: usa@ginverter.com W: www.growatt-america.com

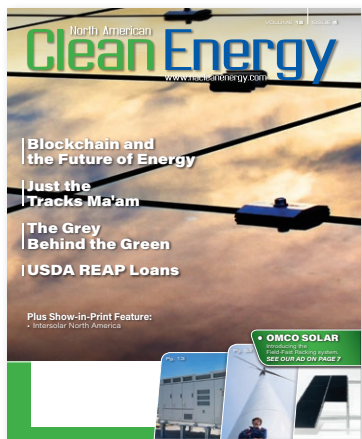

On our cover...

RP Construction Services, Inc. (RPCS) provides turnkey solutions for U.S. solar companies. This project shows First Solar Series 4 modules atop Array Technologies' DuraTrack HZ v3 solar trackers.

RP Construction Services, Inc. (RPCS)
www.rpcs.com

contents



12 Mission: Possible
Diary of a solar project



24 Solar product

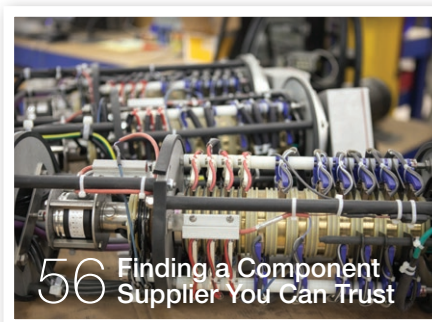

56 Finding a Component Supplier You Can Trust

48 Show-in-Print:
Intersolar North America



departments

- 8 Top story
- 10 Solar energy
- 30 Solar & energy product spotlight: Inverters
- 38 Show-in-Print: Intersolar North America
- 52 Wind power
- 62 Wind product spotlight: Filtration, Lubricants, & Greases
- 64 Energy storage
- 68 Investing in clean energy
- 72 Events calendar & advertiser's list



62 Wind product spotlight:
Filtration, Lubricants, & Greases



66 Dangers Associated with Passive Ground Fault Protection and Detection

JULY•AUGUST 2018
Volume 12, Issue 4

PUBLISHER
Ian Stuart
istuart@nacleanenergy.com

EDITORS
Jill Walters
editor@nacleanenergy.com

Meg Lugaric
meg@nacleanenergy.com

ART DIRECTOR
Chris Van Boeyen
production@nacleanenergy.com

SALES MANAGER
Ian Stuart
istuart@nacleanenergy.com

SALES
Don McIntosh
dmcintosh@nacleanenergy.com

Quinn Stuart
quinn@nacleanenergy.com

CIRCULATION MANAGER
James Vail
circulation@nacleanenergy.com

ACCOUNTING
Alison Bell
abell@nacleanenergy.com

255 NEWPORT DRIVE, SUITE 336
Port Moody, B.C. V3H 5H1
Phone: (604) 461-6223

North American Clean Energy (USPS 1370) is publishing bi-monthly and distributed free by Action Media Ltd. Periodicals postage paid at Henry, IL. POSTMASTER: Send address changes to North American Clean Energy at 515 University Ave. Suite 1, Henry, IL 61537. Subscription updates can be made at circulation@nacleanenergy.com.

North American Clean Energy accepts no responsibility or liability for reported claims made by manufacturers and/or distributors of products of services; the views and opinions expressed are those of the authors and not necessarily those of North American Clean Energy. No portion of this publication may be reproduced without the permission of the publishers.

Editorial, Advertising, Production and Circulation are at 255 Newport Drive, Suite 336, Port Moody, B.C. V3H 5H1 (604) 461-6223. Subscriptions: \$48 per year outside North America. Email: circulation@nacleanenergy.com



Printed on paper with 90% recycled fiber.

SIGN UP FOR YOUR FREE SUBSCRIPTION

Go to our website for new subscriptions, renewals, or change of address.

NACLEANENERGY.COM

Information will remain strictly confidential.

8 Blockchain and the Future of Energy	18 Just the Tracks Ma'am	56 Finding a Component Supplier You Can Trust
10 Stepping Back to Move Forward <i>The benefits of community energy strategic planning</i>	20 A Wise Choice for Low Sun PV	58 Ground Ring Grooving <i>Causes and solutions</i>
12 Mission Possible <i>Diary of a solar project</i>	30 Solar & energy storage product spotlight: <i>Utility-scale, commercial, & residential inverters</i>	62 Wind product spotlight <i>Filtration, Lubricants, & Greases</i>
14 Making End-to-End Remote Site Connectivity Possible <i>Meet the low-maintenance high-efficiency solution</i>	38 Show-in-print: <i>Intersolar North America 2018</i>	64 The Grey Behind the Green
16 Who Should Monitor Systems? <i>Asset Management vs O&M: Understanding your vendor's core competency</i>	52 Wind is Going Mainstream in Europe <i>Global valuation to exceed \$170 billion</i>	66 Dangers Associated with Passive Ground Fault Protection and Detection
	54 Automatically Lubricating Bearings in Wind Turbines	68 USDA REAP Loans <i>Fact vs. fiction</i>

Design-Build



Since 1981

Designed to Cover. Engineered for Strength.
Optimized for Solar.

► VISIT US AT INTERSOLAR SF BOOTH #9511

Baja Carport Solar Support System™
Featured Exhibit Display: Braced Single Post

Project: Metro Gateway, Riverside, CA

- Pre-Engineered
- Pre-Fabricated
- Bolted Connections
- No Field Welding
- Painted Onsite



403,325 kW | 452 Solar Panels | 146 Spaces | 24,820 sq ft

BajaCarports.com | [800] 366-9600

RATHER THAN FOCUSING ON THE WHOLE FEEL GOOD aspect of our industry, or one particular product or technology, I think it's time to step back and look at the bigger picture. Lurking just on the edge of everyone's radar is a little thing called blockchain. Actually, it's not so little. In fact, it's coming into it's own in a big, somewhat intimidating, and fantastic way. A disclaimer on my part - I was one of the people who, when I heard about a new concept for the internet called "YouTube", thought to myself, who the hell in their right mind is going to want to watch other people's home videos? Safe to say, I missed the boat on that one. Bound and determined not to make that mistake again, I will try my best to get a handle on the concept of blockchain. Yes, I've heard about Bitcoin and cryptocurrency; just don't ask me to explain them (Chuck E. Cheese tokens come to mind). I know they are collected online and traded between other people who have the same currency (so money from "The Game of Life" will not work in "Monopoly"), and that they don't necessarily translate into cash as we know it, but I'm still shaky on the particulars.

Usually, when someone describes a groundbreaking idea, I have to repeat it back in my own words - again and again - until I get it right. An abnormally brilliant mind recently spent an inordinate amount of his time, patiently waiting for me to get a handle on all he was telling me about blockchain. I'll do my best to describe the benefits of this revolutionary concept, as I understand them.

Blockchain is basically a way to communicate and share information. It offers far better security than our current system. For example, let's say a picture of an animal appears on the screen. What is it? Well, if millions of people around the world each call the animal an elephant, then it's an elephant. It is a verifiable truth, in that countless individuals define it as such. Now let's say that I want to define myself as Meg. I can join a blockchain and give a million individuals each a piece of my identity. When each of these people separately agrees that I am Meg, they affirm my identity as a verifiable truth. Millions of people all agree that I am me.

In our current system, my identity is on file with a gigantic, and centralized, entity that claims to guarantee the safety of that information. Unfortunately, if a fraudster wishes to steal my identity, he only has to break into one site. Also in our current system, companies wishing to verify my identity rely on that central brain to tell them that I am who I say I am. If someone has hijacked that information, I'm screwed.

Enter blockchain. Remember, there are now millions of people who can identify me, just as they identified the elephant. If the same fraudster from before wants to pretend to be me, he would have to somehow gain access to each of those millions of people and try to convince them that he is me.

Most investors are familiar with the old adage of not keeping all of your eggs in one basket. It's a terrible strategy where you run the risk of losing everything. Why then, do we think it's okay to do this with our most precious information? Adding insult to potential injury, this centralized system makes us pay money to use its unreliable service. Blockchain instead lets entities exchange information directly, which ends up saving money, time, and waste.

What's more, members of the blockchain get rewarded for hanging on to information. For instance, if I want to reward each of the millions of people who can verify my identity, I can give them a token. Likewise, if I agree to verify their information, they can reward me with a token. The more value someone brings to the chain, in the form of hosting, providing and/or verifying information, the more tokens that person will earn. I'm still shaky on how this translates into wealth as we traditionally define it, and the very nature of being decentralized precludes blockchain from being regulated, as we know it, so you may find yourself out of your comfort zone.

Explaining blockchain is a bit like trying to explain the Internet to someone - they have to start doing it to understand it. It may take a while to wrap your mind around all of this, but don't give up, and don't wait to learn about this transformative wave; it'll be here before you know it. Pay close attention to our feature article, and you'll start to get an idea of how blockchain is poised to change the whole way we look at energy.



Meg

"The idea of a personal communicator in every pocket is a pipe dream driven by greed."—Andy Grove, CEO of Intel 1992



"Plastic Ocean"

The pollution of the oceans reaches new records every year with patches of plastic debris in the size of entire countries. More than 1 million ocean animals are stuck in this Plastic Ocean and die each year because of this. Yet few people seem to be conscious of this scourge, which is a real danger to the biodiversity and the environment. Sea Shepherd launches, with FF New York, "Plastic Ocean" a project to put this subject on the front page of the social media and to create a mindset of sustainable usage of plastic, especially for Millennials and Gen Z. This campaign created by FF New York is made up of 3 visuals and a video which are dreamlike and colorful at first glance but highlight the sad reality of sea animals trapped in plastic waste. **Sea Shepherd** | www.seashepherd.org
FF New York | www.ffcreative.com



XPRIZE turns to the crowd

The XPRIZE Foundation announced an open call to innovators around the world to help it design future XPRIZES in five key areas: Off-Grid Energy for the Developing World, Saving Coral Reefs, Disaster Prediction, Lifting Farmers Out of Poverty, and Feeding the Next Billion. For the first time, XPRIZE will use the HeroX crowdsourcing platform to source hundreds of XPRIZE designs, and submitting teams may be selected to ultimately compete to further develop their concepts for future XPRIZES. The winning teams from the HeroX competition will win a variety of prizes valued in total at more than \$100K. This includes event airfare and hotel, and access to XPRIZE's Visioneering event; plus cash purses ranging from \$10K to \$25K. The designers of the best concepts submitted through HeroX will work with XPRIZE experts to refine their prizes before taking a global stage later this year at the Visioneering Summit. To enter Phase I, XPRIZE invites the public to choose a focus area and submit a high-level prize design concept paired with a two-minute video pitch for evaluation to XPRIZE by July 23. **XPRIZE** | www.xprize.org
HeroX | www.herox.com





Battery-less Off-Grid Solar Air Conditioning System



AC
120V, 60Hz

Mini-Split Inverter-Air-Conditioner (IAC)





4 DC Input channels with MPPT for each solar panel to maximize solar harvest. Multiple CyboInverters can daisy-chain making installation truly "plug-and-play."

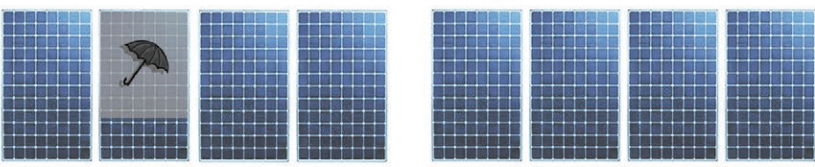

• Off-the-Grid • "Free Air Conditioning" • Battery-less or Battery-enabled • Easy Installation

CyboInverters are patented, UL certified, NEMA6 (IP67) rated & made in USA.

A CyboInverter Nx model (1.2KW) can run a 9000 Btu IAC, and its Twin-Pack (2.4KW) can run a 18000 Btu IAC. A 48V battery can be used but is not required.

www.cyboenergy.com
916.631.6313

InterSolar North America 2018

San Francisco | July 10-12 | Moscone Center, West Hall



SOLAR
OMCO

THE FIELD-FAST™ EDGE

Compatible with Any Module | Dramatically **Shorten Lead Time**

60-Year **U.S. Steel** Buying Authority | **Factory-Direct**, High Quality, **Costs Less**

Pre-Assembled Components Yield **35% Faster Builds**

Lowest Labor Cost Per Watt | U.S. Materials **Failsafe Supply**

Multi-MW Projects to **500 kW or Less**

OEM-Direct Material Buys + Total **Turnkey Installation**

In-House Design & Engineering for **Site-Specific Project Requirements**

Booking InterSolar 2018 Meetings Now

info@omcosolar.com

Strategic manufacturing locations in Arizona, Alabama, Indiana and Ohio
Business Development: egoodwin@omcoform.com | **602.352.2700** | omcosolar.com

* Field-Fast™ is a trademark of OMCO Solar.

Blockchain and the Future of Energy

by Evan Caron

BLOCKCHAIN IS COMING TO THE energy world, and its impact will be massive. It will accelerate the transition to renewables and give us real and immediate ways to combat global warming, incentivize the production of renewable energy, and replace fossil fuels.

What is blockchain?

If you've heard of Bitcoin, blockchain is the technology that powers it. Blockchain allows data to be recorded on a distributed ledger in a way that cannot be changed.

Why does it matter?

The key benefit of blockchain as a technology is that it enables parties that do not know each other, or trust each other, to do business together and still feel secure. Applications running on the blockchain can take advantage of smart contracts that trigger certain events (for example, payment) when particular milestones are met – so long as some form of proof is presented that that milestone has been met.

Together, blockchain as a technology, and the advent of smart contracts running on it, have the potential to change everything, much the same way that internet technology changed everything in the late 90s. In this analogy, Bitcoin is a lot like the Mosaic/Netscape browser. It's an example of the dramatic and disruptive effects of blockchain technology: "Look, Ma! Instead of government issuing currency, a non-profit foundation can issue its own currency and have the market determine its value!" Bitcoin is only the beginning of the many changes blockchain will deliver.

How will it change the energy markets?

In the energy sector, we expect blockchain to have a massive impact. After all, the future of energy lies in renewable energy technology. And unlike fossil fuels, renewable energy relies on a set of assets that are more dispersed. In the future, many more businesses will find it advantageous to produce their own energy and consume it. Already, prosumers are finding it advantageous to put a renewable energy power plant on the roofs of their homes – in the form of solar panels. These trends will be accelerated by the availability of low-cost battery technologies designed for both industrial and consumer use. Demand response and load management will also be key to building power plants to get to 100 percent renewable.

A distributed model

Power markets are moving from a centralized model, to a more distributed model. The fundamental conditions required to make distributed power markets work are:

- automated production and consumption tracking
- validation
- payments
- transparency
- incentives
- security

These improvements will require a distributed, self-organizing system that reduces friction, routes around regulatory obstacles, and connects fractured markets.

That's why blockchain is key. The distributed nature of blockchain provides an unprecedented level of trust and transparency. This enables businesses to feel confident in transactions that require a high degree of trust. Breaching the security of a central database is one thing – trying to fool a decentralized, global network of databases is almost impossible. The result is a reduced need for middlemen, faster transactions, and lower expenses than traditional centralized models.

We've seen the impact of this already with cryptocurrency; Bitcoin and blockchain solved the double spending problem (i.e. spending the same digital currency twice) by ensuring distributed consensus. As a result, cryptocurrencies can be spent internationally in seconds, at low transaction fees, while working around normal third-party middlemen (like banks). This has roiled the financial industry. Get ready for the same thing to happen in energy.

A fundamental shift

Blockchain will enable a fundamental shift in the distribution of energy by enabling people to trade energy among themselves. This will stimulate more renewable energy projects, and accelerate the transition away from carbon-emitting electricity generation. Tokenization will allow producers to seamlessly connect with investors.

As a result, we'll gain the ability to openly and securely verify/track/exchange energy and related data. This will strip away inefficiencies in existing markets, as well as create brand new markets. Peer-to-peer (P2P) energy trading marketplaces will use blockchain to create an immutable, open, secure, and decentralized record of transactions.

The result will be automated processes and transactions, significantly reduced costs, and inherently trustworthy sources of verified data. Also worth mentioning: Enabling data-driven investments will include traditional utilities, not destroy them. They will allow smart cities, municipalities, city planners, and communities to adopt new technology, and cooperate to reduce climate change, provide cleaner and cheaper energy, and create a more secure power grid.

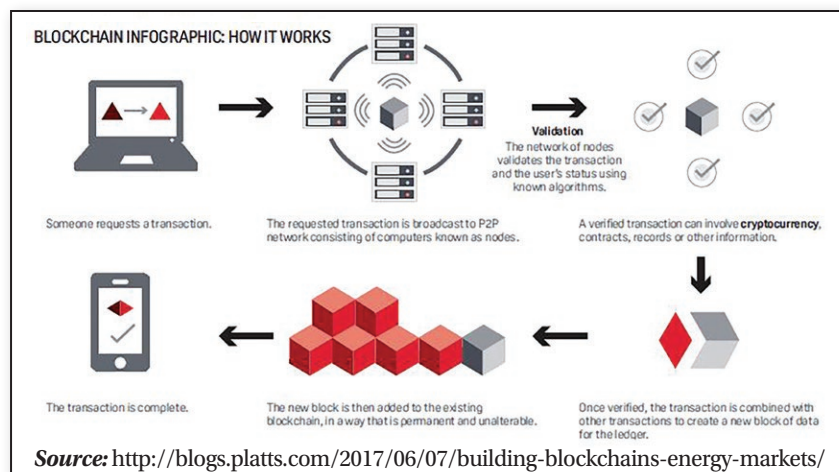

Benefits

Some examples of how blockchain will help the energy sector...

Open up markets:

The ability to aggregate and exchange secure and trusted data opens carbon offset markets to the approximately 90 percent of carbon emissions not covered under existing programs.

Eliminate middleman fees:

People who have rooftop solar systems often have to pay a hefty fee to the utility company. The blockchain will eliminate these fees.

Improve reporting:

The current reporting system is flawed; data is often self-reported ("I made four kilowatts" or "I hired a consultant."). Plus, it's very expensive. Instead of going to a utility and just sitting there, data will be immutable, open, and verified.

Reduce waste:

The blockchain will minimize fraudulent energy production data. By capturing immutable proof of energy production, running open-source estimators to verify, and layering in blockchain to enhance security and trust, this challenge can be solved in a relatively low-cost, low-touch way. This not only cuts down on bad actors and bad data, but also creates a more robust incentive market by improving trust and accuracy.

Fix renewable energy incentives:

Incentive programs have been around for decades, but they're plagued by fraud, and ineffective at addressing the core issue of carbon emissions. Additionally, these programs tend to be location-specific, relatively complex to participate in, and onerous to administer. Blockchain, smart meter, and "oracle" technologies will establish a more trusted, efficient, and effective system for tracking and rewarding carbon displacement via renewable energy production.

Reduce shipments:

Blockchain will help create an increasingly decentralized logistics process (compared to today's highly centralized version). The ability to administer even the smallest shipments at minimal cost translates into a reduction in shipments. This, in turn, will lessen the need to pool everything together in big warehouses.

The right mix

The next iteration of the energy grid will be powered by generation on demand, distributed energy resources, highly efficient demand, and a commons approach to resource management. While blockchain is at the core of the solution, the need for automated and secure data feeds, and AI and machine learning marketplaces, are also key. With the right mix of these technologies, we'll see more efficient markets for carbon offsets, data transmission and validation, and clean energy stemming from renewables. The rewards will go to people, companies, and other organizations that make a meaningful and measurable difference in reducing the emissions that endanger our planet.

Evan Caron has over 15 years of experience in the US commodity and energy markets working with Wall Street investment banks (Morgan Stanley, Deutsche Bank), global energy merchants and private equity-backed energy investment companies. His unique experience stems from trading domestic energy power systems during a rapid growth of renewable energy and demand response integration. Caron is the co-founder of Token Commons Foundation and managing director of Swytch, which is an Austin-based blockchain platform that tracks, verifies, and rewards those reducing the global carbon footprint.

OVER 3.2 GW SOLD
Every System For Your Every Need



GENIUS TRACKER™ WORLD'S HIGHEST POWER PRODUCING SOLAR TRACKER

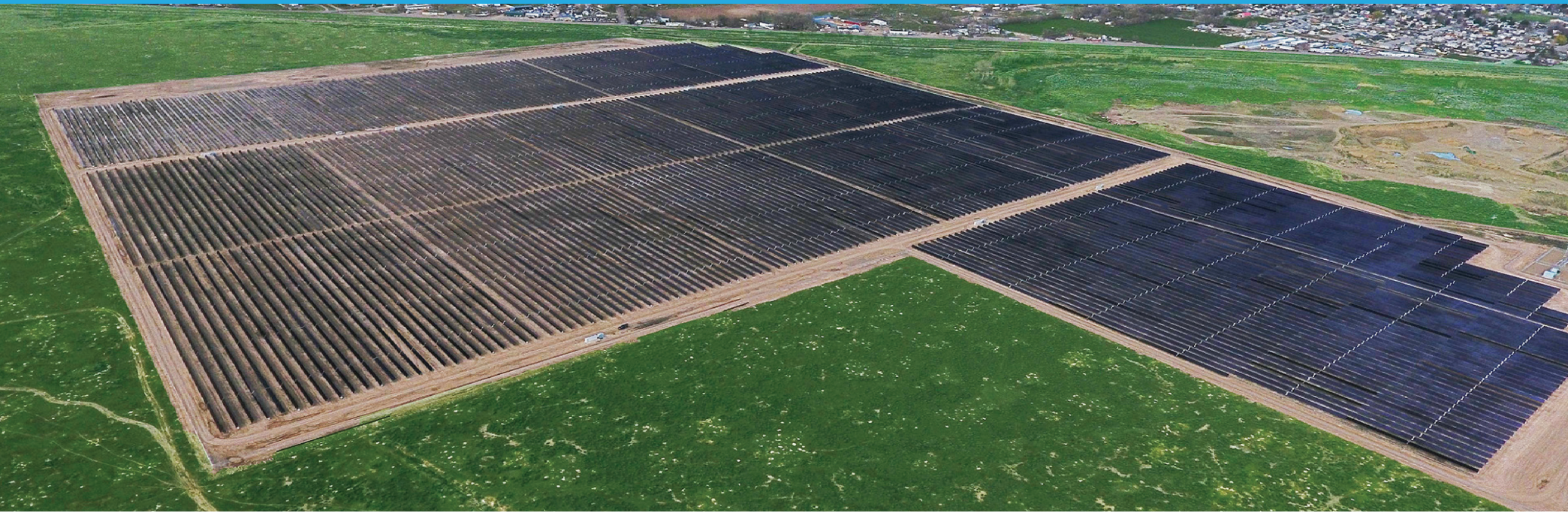

OWNER BENEFITS
HIGHEST POWER PRODUCTION
AND LOWEST O&M COST

COMBINE TO INCREASE OWNER CASH FLOW OF SAMPLE PROJECT TO \$17MM CASH FLOW VS \$13MM & \$15MM FOR COMPETITORS

+^{UP TO} 5%
Higher Module Density
Increased Row Spacing Allows for More Time Facing The Sun and Less Time Running Away From The Shade

+^{UP TO} 1.25%
WeatherSmart™
AI Technology Optimizes Tilt Angle Based On Weather Data To Maximize Power Production

+^{UP TO} .5%
PowerBoost™
Smart Optimization Allows Table Rows To Respond Individually Based On Topography To Prevent Shading

UP TO **6.75% MORE POWER PRODUCTION**
AND UP TO 40% HIGHER ROE
LOWEST O&M COST

Lowest grass cutting & module washing cost
Zero maintenance drive system

INSTALLER BENEFITS
FASTEST INSTALLING SYSTEM

ADVANCED DESIGN INNOVATIONS AND PRE-ASSEMBLED COMPONENTS

Pre-Assembled Drive Arm
Industry's Fastest Installing Drive System

50% Faster Than Typical Competitor Drive Systems



ONE WORKER LIFT
NO MACHINE REQUIRED

SpeedClamp™
No Mounting Hardware
Speeds Module Installation Up To:

40%

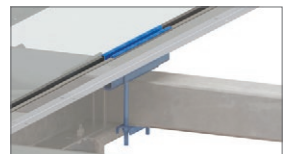
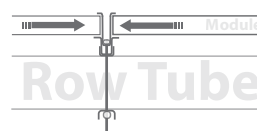

QuikClamp™
FSLR Series 4 Module
Installation Speeds Up To:

30%

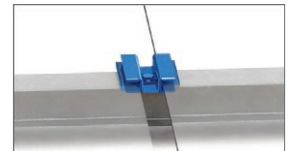

Every System For Your Every Need



P: 212-388-5166 | gamechangesolar.com

VISIT US AT



BOOTH 9421
JUL 10-12, 2018
SAN FRANCISCO, CA



BOOTH 1388
SEP 24-27, 2018
ANAHEIM, CA



Stepping Back to Move Forward

The benefits of community energy strategic planning

by Jeffrey Domanski

Community energy strategic planning is a crucial first step for cities and counties looking to reap rewards in today's changing energy landscape.

When making significant decisions in life, it's often wise to step back and take a look at the big picture to help assure you're taking the right course. This is especially true when many paths can be taken. Such is the case for local governments, when it comes to energy-related opportunities. Cities and counties, big and small, are reaping the economic benefits by doing just that.

The Changing Grid

A radical change is underway regarding how electricity is produced, transmitted, distributed, and purchased by governments and consumers in the United States. The U.S. electricity system has historically relied on centralized power generation, with long-distance transmission to local distribution systems delivering energy to customers. The American Society of Civil Engineers (ASCE) 2017 Infrastructure Report Card notes that most of the electric transmission and distribution lines, also known as the grid, are more than 50 years old, well beyond their life expectancy. The current grid is unable to meet today's electricity demand, especially when you factor in the growth of renewables like wind and solar. Extreme weather events have proven the grid to be highly vulnerable to disruptions. Further, only about one-third of the power produced at today's power plants reaches customers. In order to improve this system, ASCE's report indicates that \$934 billion is needed over the next 10 years.

Rather than continuing to pour money into this inefficient grid, innovative thinkers are looking to create a more distributed system; one that calls for action at the local level, and creates cost-saving and revenue-generating opportunities. In addition to reducing electricity demand through energy efficiency measures, local innovations include local power-producing projects such as gas turbine generators, private solar installations, community-based energy solutions like community solar, electric-vehicle systems, smart meters, and microgrids.

Investing in Energy

Despite consistent and increasing investment in energy efficiency and other energy strategies, the potential to reap economic and other benefits from these projects remains huge. The International Energy Agency's 2016 Energy Efficiency Market Report indicates that, while the U.S. invested over \$6 billion dollars in energy efficiency in 2015, fully two-thirds of the market potential for energy efficiency is still up for grabs. The global energy efficiency market alone is expected to grow to \$30 billion annually by 2028. A 2013 U.S. Department of Energy (DOE) market analysis found that 70 percent of state and local governments had not taken advantage of existing opportunities. This doesn't even include the benefits associated with renewable energy projects.

Before leaping toward any one of these opportunities, however, it's vital for communities to know how energy is being used, the resources and data required for each opportunity, and how they are related. This information allows them to prioritize and plan efficiently.

Community Energy Strategic Planning

The DOE's Guide to Community Energy Strategic Planning (CESP) is widely accepted as the best practice for these purposes. CESP's emphasis on the role of the leadership team, and engagement of community stakeholders, aligns with the administrative and outreach efforts required for most energy projects. It also provides insight into how strategies could be combined to minimize costs, and optimize benefits.

The process may sound daunting, but it helps communities gain the insight necessary to pursue the most beneficial activities, reduce the burdens associated with entering the energy market, and invest in infrastructure and public programs. The DOE confirms that, "in a time of tightening budgets... developing a Strategic Energy Plan can be an important component of good governance, and it can also put governments in a prime position to capture funding opportunities as they arise, because they have proactively identified their goals and priority actions."

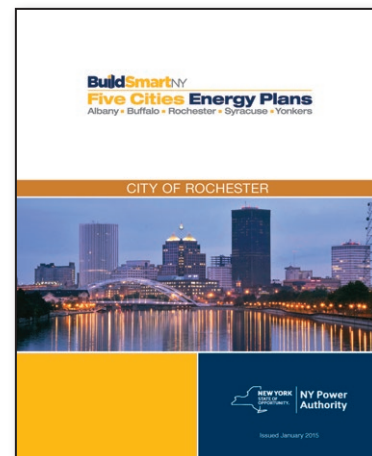

Community Energy in Action

The following communities are taking this step back to move forward confidently:

- Frederick County, Maryland, completed its Comprehensive Energy Plan in 2010, and achieved \$358,000 in energy savings through building projects and vehicle fuel conservation in 2011 alone.
- Following the guidance laid out in its 2010 Community Strategic Energy Plan, Arlington County, Virginia has built 32 energy-saving "green buildings." As of 2016, by using strategies that included LED lighting, increased insulation, and high-performance heating and cooling equipment, the equivalent of energy used in 1,600 homes has been saved.
- The City of Rochester, New York, completed an Energy Plan in January 2015, and has prioritized lighting retrofit projects. In its first round of projects (in which T8 fluorescents were replaced with LED) Rochester yielded \$231,000 in annual savings. A recently announced \$840,000 grant from New York State will support replacing lights in 17 community centers and three municipal facilities, which will yield another \$90,000 in annual savings.
- A building energy analysis in Boise, Idaho, as part of their 2017 Community Strategic Energy Management efforts, led to a sharing of design best practices across locations, and awareness of the 17 buildings that consumed 70 percent of the City's energy. This included fire stations that will benefit from design upgrades.

WATTNODE®

Power (kW) and Energy (kWh) Meters for Solar

Revenue-Grade and Standard AC Metering

PV Production Metering • Consumption Metering
Net Metering • Zero Export Metering
Battery Storage Metering

Continental Control Systems, LLC

1-888-928-8663

sales@ctlsys.com

www.ctlsys.com

Socomec Group

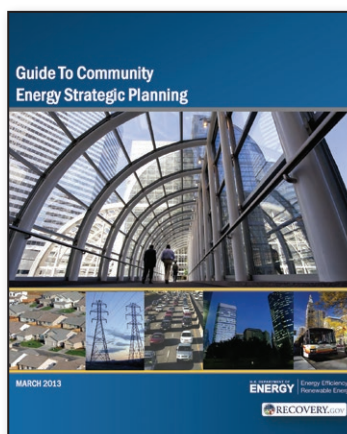



IBTS is a 501(c)(3) non-profit organization that works to build resilient communities by reducing risk, enhancing public safety, and improving quality of life. Services include: Building and Community Development, Energy and Sustainability Services, Disaster Planning and Recovery, Quality Assurance, as well as Compliance and Risk Monitoring. IBTS's work is guided by a Board of Directors made up of government officials appointed by state and local governmental associations, including the Council of State Governments (CSG), International City/County Management Association (ICMA), National Association of Counties (NACo), National Governors Association Center for Best Practices (NGA Center), and National League of Cities (NLC).

IBTS | www.ibts.org

- The City of Denton, Texas, 2012 Sustainability Plan has helped the city reduce its greenhouse gas emissions by 20 percent from its 2006 baseline, with 45 percent of city customers receiving power from renewable sources.

These studies allowed the pursuit of projects, many of which were supported by grant dollars made available because they analyzed the opportunity, and were able to show the resulting energy and greenhouse gas reduction. In addition to the economic benefits, many of these communities have shown gains in:

- Job creation for the local economy
- Greater energy security, and influence over energy choices
- A cleaner environment, and increased livability
- Improved communication across leadership and with the community, which will enhance other local government efforts

There are many ways to start your strategic energy planning process, and many resources available to help you. A visit to the DOE's Community Energy Strategic Planning site is a great first step. By taking a step back to move forward on energy projects, your community will unlock savings, and give you a view to a landscape of economic and other opportunities.

Jeffrey Domanski is Senior Manager, Energy, Sustainability and Resilience at IBTS. He focuses on energy planning, professional education and training programs, in addition to municipal toolkit and engagement platform services. Prior to joining IBTS, he was director of sustainability and energy at Courtney Strong Inc., director of sustainability strategies at Cushman & Wakefield, and co-director of sustainability at Princeton University. Mr. Domanski serves as a committee member on the Council of State Government's (CSG's) Energy and Environmental Public Policy Committee and was selected to serve on the board of the Upstate NY chapter of the U.S. Green Building Council (USGBC).

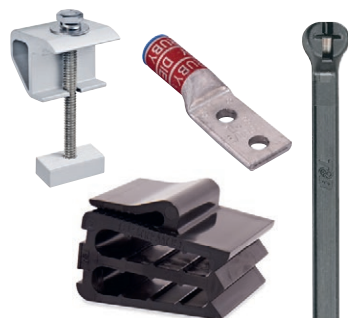

Solar Power Systems

Quality in each component.

Whether you're working in solar OEM, or as a contractor, the quality of essential electrical components is key to an optimum solar power system. Our solar capabilities and products cover wire management, grounding, shut-down devices, inverters, surge protection, circuit breakers and switches, and more.

For more information contact your T&B distributor or T&B representative, or visit tnb.com/TBSolar

tnb.com

© 2018 Thomas & Betts Corporation. All rights reserved.

Thomas & Betts
A Member of the ABB Group

Mission: Possible

Diary of a solar project

by John Hoffman

MAKING PEOPLE MONEY IS MORGAN STANLEY'S

primary objective. Last year, however, the owners of the Morgan Stanley building in Irvine CA focused on something that made financial sense for them: installing a solar energy system by year's end, to both produce on-site renewable energy and take advantage of the associated tax benefits. Although Morgan Stanley's Irvine, California office is located nearby dozens of other businesses and office buildings, it also happens to be within shouting distance of John Wayne Airport; proximity to a commercial aviation site that handles international flights posed a potential zoning headache. The company laid out the following challenge: armed with a signed contract in mid-June, the contractor was given explicit instructions to plan, start, and finish a massive, 404kW solar canopy, by December 31st.

In early July, the contractor met with the City of Irvine to present the design rendering. The Head of the City building department looked at the 3D model and said, "This is impossible." Nothing is impossible, of course. After all, if it's possible to build 100-story skyscrapers, why is it impossible to cover the top deck of a parking lot with solar?"

By mid-July, the city received formal plans that classified the canopy as a shade structure. That was a no go - the plans were kicked back with instructions to resubmit them under the guise of 'New Building (CNEW)'. According to the city, erecting a canopy was akin to adding an entire floor to the building. (Building a canopy apparently follows the same planning and permitting as construction of a brand new building.) An architect had to be brought in to satisfy building code issues with regards to parking, occupancy, height, etc.

Then there was the airport. Apparently, solar panels needed special dispensation to soak up the sun. John Wayne Airport, in addition to serving as the gateway to Disneyland (and boasting the reputation as one of the country's scariest airports, thanks to a shorter runway and steep takeoff angles), is also classified as a primary commercial service airport. This basically meant that no extra floors/canopies/new buildings were getting permission without a full FAA review. Translation: the application had to go through 10 departments within the agency. Lots of anxiety - and, 45 days of review later - it was passed.



The official permit still had to make its way through a jungle of bureaucracy. Without a permit in hand, it was a gamble to start the off-site fabrication of steel in September, but there was no other way the canopy would even have a chance of getting completed by year's end.

In early November, when the permit finally arrived and construction was given the go ahead, it appeared that the gamble had paid off. The site had been

scanned, the steel was in motion, and the columns, beams, and purlins arrived on November 20th. Teams of skilled laborers swarmed the rooftop. The action began on the south end of the structure, installing the steel skeleton of the canopy. Then the solar panel installers chased the steel workers from south to north.

On a typical sunny southern California day, December 12th, the last panel was put in place. An achievement, to be sure, but that left just 19 days to make the building owners' strict deadline. Although the solar canopy sparked in the sunlight, it wasn't connected to anything.

Over the next two weeks, the race was on to trench 500 feet through landscape, hardscapes, curbs, sidewalks and core. Only then would the system be able to connect to the building's main service panel. In a matter of days, the inverters were hung, the system was fully wired, and it was all plugged into the building's power center.

If you ever happen to be flying out of the John Wayne Airport, and want to get your mind off the disconcerting angle of the plane's takeoff, look for a giant solar canopy atop 1901 Main Street (northeast corner of Main & MacArthur) - you'll be



able to see a modern engineering miracle of sorts. Even though the City of Irvine said the mission was impossible, the solar system has been up and running since its commissioning - offsetting building energy load and generating tax incentives for the system owner.

John Hoffman is the CEO of SunGreen Systems, a full-service solar contractor in Southern California that specializes in solving solar energy challenges for their clients. John has 11 years of experience in the fields of sustainability, solar energy integration, and LEED construction.



Connectivity and Safety of PV Systems are our Top Priority



1000v Brach connectors



Replaceable PV In-line Fuse holder, 1000v or 1500v, UL Listed

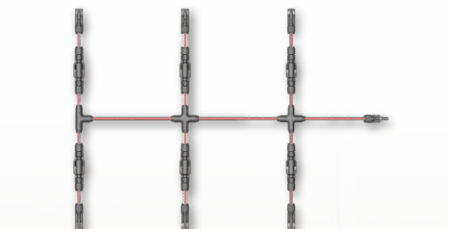

6 string T&X type harness with fuse



Y's harness

Phone: 650-283-1122

Email: info@awtsuncon.com

www.awtsuncon.com

1360 Union Hill Road, Suite 5A

Alpharetta, GA 30004

SunGreen Systems
sungreensystems.com

freesun®



freemaq®

POWER ELECTRONICS® PURE ENERGY



HEM | HEMK

- UL1741SA Certified Unique Central-String Inverter Design
- 2.0 to 3.5MVA Output Power
- Flexible Design - Integrated MV Transformer & Switchgear <HEM>
- Stand-alone Inverter <HEMK>
- State of the Art Cyclone Air-Cooled System
- IP65/NEMA 3R Degree of Protection without Filters
- Field Replaceable Power Conversion Modules
- No Focused Training Required For Module Replacement
- NEC 2014/NEC 2017 Compliant DC Disconnection Option
- Integrated Auxiliary Power for Customer SCADA and Trackers
- Configurable Grid Management Feature
- Standard DC Insulation and Zone Monitoring

AC | DC COUPLED SYSTEM

2.0 to 3.5MW
0.5 to 3.0MWh

HEM | HEMK Series Inverter
DC/DC Converter
Battery Management System

TURN KEY SOLUTION

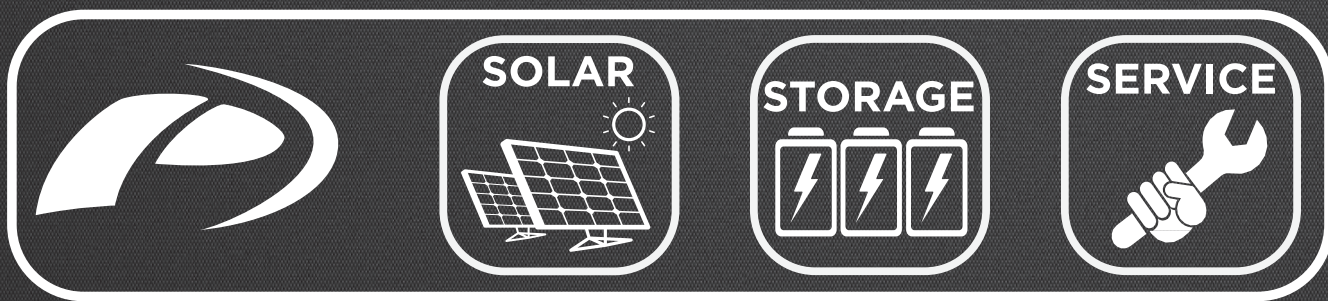

EXPERIENCE

- +30 Years of Power Conversion Experience
- +6 GW Installed Worldwide
- +300 Utility Scale Projects and +2GW Installed in USA
- 13 Service Hubs Throughout USA
- 24h *POWER ON SUPPORT*



Power Electronics USA
+1 (602) 354-4890
sales@power-electronics.com
@PE_EasyToDrive
www.power-electronics.com

VISIT US
BOOTH 8229

inter
solar
connecting solar business | NORTH AMERICA

Making End-to-End Remote Site Connectivity Possible

Meet the low-maintenance, high-efficiency solution

by Steve Sybeldon



POWER PLANT OPERATORS FACE DIFFICULT

decisions in selecting the right communications systems. When these plants are located away from city infrastructure, direct cable access is too costly, and existing wireless solutions can also be both costly and ineffective. The Cypress Creek Renewables plant in Ontario, Oregon (which relies on satellite services provider FMC GlobalSat) is a perfect example of this situation. To date, satellite has remained a nonviable solution due to cost, size, weight, difficult commissioning, etc. In this day and age, the fact that field engineers must resort to using thumb drives to transfer critical information is time consuming, inefficient, and costly. They should be able to maintain and monitor facilities remotely.

Current satellite solutions deployed by plant operators use fixed dishes that are precisely pointed directly at the satellite. During inclement weather, which is frequent in remote locations such as the Cypress Creek plant, wind occasionally blows the fixed dish out of alignment with the satellite. As a result, a highly-trained satellite technician must come out to repoint the dish. Not surprisingly, remote locations report they experience many outages per year. Where field callouts should be reserved for necessary equipment maintenance, companies find their bottom line

being eaten away by callouts that are mostly dedicated to bringing communications back online. Additionally, the utility offtaker consistently loses visibility into the asset, raising data reliability and safety concerns. Slow and spotty communications at best, coupled with uncontrollable variables such as weather and environmental challenges, pose a high risk of closing down the plants altogether. The renewable energy industry must have a better alternative.

Obstacles

For plant owners, the travel time to a remote destination with an installation crew can be extremely costly. These legacy systems require precise pointing to the satellite in order to get and maintain a connection. Additionally, the environment itself can block communications; wind and other poor weather conditions, which are inherent in more barren remote locations, invariably cause loss of signal. This frequent signal loss interferes with the accuracy of asset monitoring and reliability. Historically, data issues caused by environmental phenomenon (such as rain fade) are the result of significant latency and packet loss. These results are typical of slow satellite transmit speeds, which then cause receiving terminals to time out and lose data.

The time and cost to deal with a thousand or more outages per year is neither sustainable nor affordable, for any operation. Every time connectivity is lost, communication to the plant owner and the utility company shuts down. Consequently, plant operators report that this level of operational maintenance has become their only job.

Future Proofing

Satellite solutions rely on geostationary earth orbit (GEO) satellites. In less than two years, however, several low earth orbit (LEO) satellite constellations will come online. These new constellations will offer higher performance and significantly lower latency than their GEO predecessors. Unlike GEOs, LEOs will move from horizon to horizon in mere minutes, necessitating new terminals to track the fast-moving satellites. Terminals will also need to have instantaneous switching capabilities to ensure uninterrupted connectivity. As the satellite that the terminal is linked with moves out of view, the terminal will need to form a new beam to catch the next satellite as it comes into view. This switch from disappearing satellite to

1500VDC PV FUSE HOLDERS:
INTRODUCING THE
NEXT LEVEL OF SAFETY,
DURABILITY, AND EASE
OF INSTALLATION

FLEXIBLE • VERSATILE • GLOBAL



US15M1HEL
• BUS BAR
TERMINAL
• ULTRASAFE™

HP15FHM32A

• SCREW CLAMP
• LOCK OUT TAG OUT
[LO/TO]
• UL 94 V-0



HP15FHM32B

• CAGE CLAMP®
• METER/PROBE
ACCESS
• UL 94 V-0

EP.MERSEN.COM

VISIT BOOTH 8121 AT
EES/INTERSOLAR
JULY 10-12, SAN FRANCISCO, CA
TO LEARN MORE

MERSEN
Expertise, our source of energy



appearing satellite will need to happen within milliseconds to avoid dropped connections and service interruptions.

The renewable energy industry will consistently seek efficiencies through technological improvements that minimize time and costs incurred in maintaining power energy plants, many of which are increasingly found in remote locations. Operators demand instant results. Their priorities are to reduce overall field call outs to the site, so that their plant technicians can focus on maintaining maximum uptime, not communications failures.

The more self-operational plants become, the lower the cost of plant ownership. Alleviating physical challenges and improving self-correcting satellite connectivity is a major goal, not only for Cypress Creek Renewables, but every power plant looking to boost productivity. Environmental challenges are inherent to our business. Emerging technologies such as a high-performing managed network, coupled with steady, reliable, weather-resistant satellite antenna technology, will translate into huge growth potential for the industry.



Steve Sybeldon is President of Business Development and Sales at Kymeta. He is responsible for promoting Kymeta communications solutions to Land Mobile, Maritime, and Fixed location markets. Steve is a cellular industry veteran with 20 combined years at MCI, McCaw Communications, and AT&T Wireless. In 2005, he transitioned to the satellite industry to deliver cellular services within the maritime industry by way of satellite link.

Kymeta | www.kymetacorp.com



Flexible and economical RSS

Midnite Solar's MNL SOB, "Little Shut Off Box", system is made up of a transmitter and one or more receivers. A transmitter is located in or near the inverter wiring compartment and the receivers wire directly to the module just like an optimizer. The system can be used for string or module level shutdown to meet 2014 NEC or 2017 NEC "National Electric Code." The transmitter induces a PLC signal into the existing PV wiring, no need to install any additional wiring in between. When Rapid Shut Down is initiated, the transmitter ceases sending out its signal and the receiver shuts down the array. The MNL SOB's easy installation on new or existing systems and ability to work with any brand of solar panel or inverter on the market make it a flexible and economical rapid shutdown solution.

Midnite Solar, Inc. | www.midnitesolar.com

Your Wishes Are Granted...

- Proven Safe Operation • Partial State-of-Charge • Rapid Charge Acceptance
- BMS • High-Temperature Solutions • Longer Life • Recyclability

Advanced Lead Battery Technology Is Here

Beka
SOLAR
PHOTOVOLTAIC BATTERIES

MK Battery
An East Penn Manufacturing Co. Subsidiary
MADE IN USA with U.S. and Imported Materials

- Competitive Warranty • Quality systems certified to ISO9001 • U.L. recognized components
- Available through MK Battery distribution centers across North America, Europe and the Asia Pacific region.

mkbattery.com © MK Battery 2018

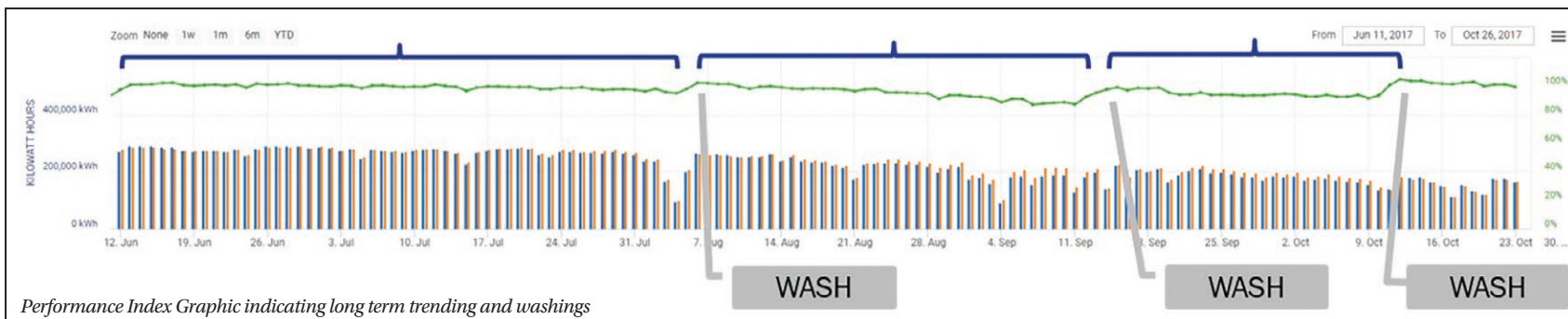

Who Should Monitor Systems?

Asset Management vs O&M: Understanding your vendor's core competency

by Caitlin Blaisdell

During development and construction of a solar PV asset, the monitoring hardware is carefully considered. However, owners often overlook the importance of considering who should be responsible for actively monitoring the systems. The two most common vendors that perform monitoring are the operations and maintenance (“O&M”) provider, and the asset manager (“AM”).

What is the difference between the AM and O&M provider's monitoring and reporting? It comes down to the core competencies of each vendor, and their incentives. Asset managers and O&M vendors approach systems differently. Typical industry practices incentivize O&M vendors to focus their monitoring practices to maximize their fees; this often leads them to conclude (prematurely) that every alarm warrants a truck roll (i.e. added expense). Asset managers, on the other hand, are incented to improve the overall bottom line of the project, not just production. If an owner is more interested in optimizing long term technical and financial performance, the primary responsibility should reside with the asset manager, as an Asset Manager can present an objective opinion on when a cost for maintenance is warranted.

are only looking for material outages they can repair. They look primarily at binary faults and equipment outages rather than more granular system performance. O&M vendors are incentivized to roll a truck for every alert and alarm.

Asset Management Vendor

On the other hand, asset managers are incentivized to:

1. Maximize Performance - both technical and financial.
2. Take a proactive and holistic approach to monitoring (consider operations + financial + contractual considerations when diagnosis and dispatching)
3. Understand and identify long term trends (character history of the plant as it relates to the future health of the plant)
4. Apply knowledge gained from monitoring across all portfolios, and share their experience with asset owners
5. Keep the asset owner informed throughout the ticketing lifecycle (dispatch and resolution)
6. Employ oversight of O&M vendors and advocacy, on behalf the project and project owners

Asset managers employ the philosophy “Think twice, roll once.” It is often not financially prudent to roll a truck without: 1) understanding what has previously happened on a site, 2) doing a full diagnostic of the alarm, and 3) understanding how rolling a truck affects the financial and contractual health of a system. If, for example, a string inverter goes down on a utility scale site, an O&M vendor (who is obligated to react to an

O&M Vendor

O&M providers monitor systems to comply with specific maintenance obligations. O&M providers are contracted with the project or project owners to:

1. Maintain planned production
2. Fix what's broken (act in a reactionary response to alarms and alerts)
3. Perform necessary OEM maintenance (keep up warranty)

O&M Incentives

O&M vendors, in their standard defined role, are technician-based vendors who have very limited desktop review and obligations for reporting. Most O&M departments don't have access to detailed forecasts. They do not carry out trend analysis or comparative analytics, and

American Earth Anchors
The best screw you will have in the dirt™

46" Penetrator™
Field-tested to 9,000 lbs downward pressure

REPLACES CONCRETE FOOTINGS

- No digging
- No pouring
- No forms
- No waiting

EASY LEVELING Screw down, screw up

2" Schedule 40 pipe fits over
Custom brackets for any pipe size

Visit us at SPI! Booth # 2796

americaneearthanchors.com
corinne@americane.com 1-508-520-8511

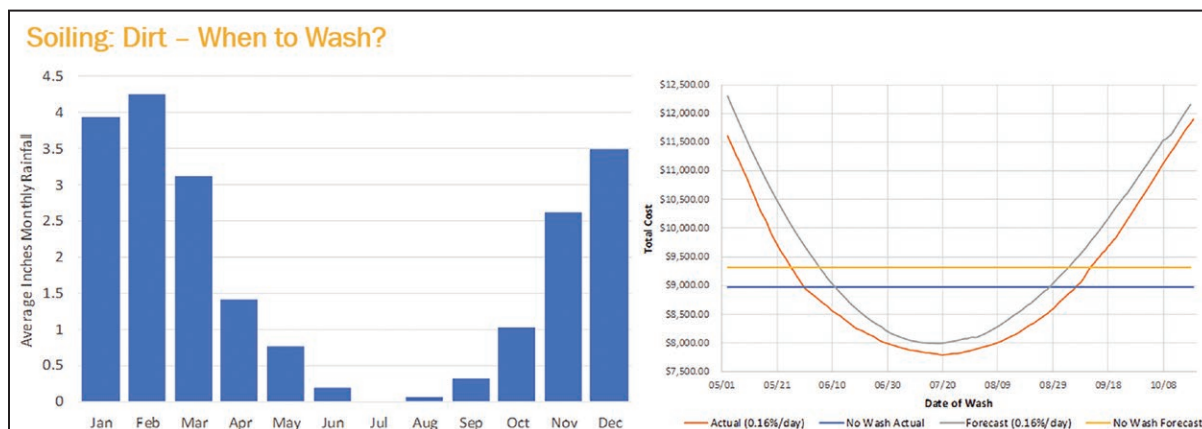

outage) would most likely dispatch a truck to the site. A cost benefit analysis done by an AM, however, could potentially show the optimal time for a dispatch that could combine a repair with a planned site visit, saving the cost of a one-off truck roll.

Asset Management Incentives

Asset Managers have varying incentives. Not only are they incentivized to maximize performance, they are involved with multiple stakeholders of the project that have varying goals and needs. Investors, owners, and operators use this reporting to make proactive decisions. Third party asset managers are further able to apply what they have learned to all portfolios under their management; the more portfolios and varied equipment they monitor, the greater their ability to manage portfolios, with higher efficiency. For example, after closing out an alarm, an AM will check other systems to ensure that a similar problem doesn't exist for sites that are located near the system, have similar designs, or have similar equipment.

Case Study: Monitoring & Soiling

O&M Vendors don't necessarily take monitoring and trending into account when dispatching a module-washing vendor. They are less focused on optimizing the timing of that wash. An asset manager knows that when it comes to soiling, **understanding long term trending through diligent monitoring** is paramount to tracking lost revenue. For example, tracking weather patterns, agricultural harvesting times, types of snowfall, mining operations, or other local specific activities, can lead to better judgement when developing a washing plan.

Asset managers objectively ask a vital question: **Is the expense worth the lost revenue?** They consider the type of soiling on a site, the immediate weather trends (such as if an area is expected to have a high amount of rain), and long-term weather trends. A good asset manager would know that sites in the southeast, that aren't located near construction or agricultural sites, rarely need washings; an O&M vendor is incentivized to sign up a contract with module washings, regardless of location.

So, who should monitor your system?

Oversight of the technical health of a portfolio is key to maximizing energy production and asset longevity. Traditionally, O&M providers have been expected to provide first line defense around production and monitoring performance. It is important to note that this first line is often insufficient and (in some cases) counterproductive, given the incentives guiding the O&M provider and their limited knowledge of external factors influencing plant performance.

An asset manager is better positioned to have a deeper view of what solutions are optimal and cost effective, given their more comprehensive understanding of the internal and external factors affecting the plant, stakeholders' goals, contracts involved, and financial goals of the investor.

Caitlin Blaisdell is the Director of Commercial Operations and Marketing with Radian. Radian Generation is a team of solar industry experts who provide comprehensive asset management services to solar and wind projects. Radian is contracted to provide services to over 5GW of operating plants in over 15 states, and in three countries. Caitlin manages the inside sales team and supports business development efforts. She joined the team in 2014, after working in sales and operations with a solar racking company. She holds an M.S. in Negotiation from Columbia University, and a B.A. in Peace, War & Defense from the University of North Carolina, Chapel Hill.

Radian Generation | radiangen.com



Everything Under the Sun



From quality products and customized configurations, to warranted connections with reliable tools, BURNDY saves you time and money by being your single source for all solar installation needs.

- Wiley Bonding, Grounding and Wire Management Products are the most recognized brand within the solar market.
- UNIRAP™ Cable Ties, including Nylon 12
- Flame-retardant Heat Shrink
- ACE Conduit boxes
- BURNDY® HYGROUND® Compression Connectors
- PATMD6 IN-LINE® Crimper/Cutter
- BURNDY® Engineered System — Our dies, connectors and tools, when used together, form a trusted UL Listed connection. Connections made with the BURNDY® Engineered System are backed with a 5-year warranty.



 **BURNDY**

Connecting Power to Your World®



© BURNDY LLC, 2017

www.burndy.com

Just the Tracks, Ma'am

by Tim Murphy



THE SOLAR PV TRACKER SUPPLY MARKET IS IN THE throes of commodity product perception typical of many B2B markets and products. However, significant differences remain between tracker alternatives, and tracker supply companies.

Some tracker companies are addressing the situation with the classic formula - differentiating with adders that improve top-line revenue and soften the trackers low-margin blow. Other companies remain true to the tracker mission to find lower cost electricity for customers in large-scale applications, often in the harshest environments on earth, and always conscious of cost.

The customers of industrial-grade ground-mount trackers know about this adder formula too, and about features that may not add value in the tracker mission to find them lower cost electricity. Many customers are thinking like Jack Webb: just the "tracks", ma'am.

Solar PV trackers exist to increase the yield performance of installed PV power. Trackers are best compared on their yield-gain elements, and their standard features of agile application and operation.

Yield-gain

Yield-gain elements arise from both standard and site-dependent tracker features. Standard features include tracker module-fill, site-fill options, bifacial module compatibility, and tracking arc. Site-dependent features include asymmetric backtracking, and otherwise comprehensive tracker position control (appropriate to the challenging but straightforward mission).

Agile application and operation

Agile application and operation features exhibit synergy with yield-gain elements by achieving double-duty of increasing yield-performance and/or reducing costs, that together drive down the cost of electricity. They inherently resolve more project challenges with less special effort in design, supply, installation, operation, and maintenance. Agility comes from fewer parts and operations all along the supply chain -from plant design to commercial operation- and from greater inherent tolerances of project variables, both dimensional and logistical.

Innovation

The specialist segment of solar PV tracker technology is characterized by manufacturers who have innovated products and supply chain operations in commercialization since the early 2000's. In 2017, more than 15 contenders made up the global tracker supply market of 14.6 GW, with the top three taking 52 percent market share. Two of those three offer independent-row trackers, and one provides for complete tracker module-fill and 5 percent yield density advantage as a standard feature. Independent-row trackers took 69 percent of the 2017 global tracker market.

High Precision Instruments for Solar Energy and Meteorological Research.

eko-usa.com

EKO
Beyond Accuracy.



Today, segment customers are excited about (and moving forward with) bifacial tracking applications that can achieve up to 30 percent yield-gain over monofacial tracking. Annual average bifacial gain of 13 percent has been documented at the La Silla bifacial test-bed application.

One of the top-three tracker products for drop-in bifacial optimization provides for drop-in bifacial optimization to eliminate torque-tube shading on the backside, and best reduce backside shading influences of foundation piles, exposed cable management, and mechanical links and dampers. Moreover, bifacial capture is enhanced with wider reflective ground surface, higher module mounting, and comprehensive tracker position control applied to bifacial needs. Synergetic agility features include fewer foundation piles-per-MW, double the washing/gardening rate MW-per-pass, greater site-filling options, and greater maintenance access.

The **site-dependent features** of yield-gain elements are principally backtracking, and additionally comprehensive tracker position control that impacts yield-gain according to project-specific conditions of climate and terrain.

Asymmetric backtracking control is that part of comprehensive tracker position control that avoids inter-row shading in the early and late-day hours due to uneven terrain influences. Programmed asymmetric backtracking control achieves up to 6 percent yield-gain over standard tracking.

Programmed backtracking control is superior to response control on shading of an auxiliary PV module that adds cost, occupies viable yield-area, and introduces latitude and seasonal dependence in power-supply design, supply, and installation.

Programmed backtracking control is based on NREL sun-position data, versus programmed terrain irregularity parameters that do not change with time or normal external influences. It assures robust plant operation, independent of external communications, and is complemented by secure data communications via web for offsite operations. Programmed control is of zero maintenance and provides for hardware independent software update.

Programmed backtracking control achieves both yield-gain and agility benefits in tracker technology, by enabling cost reduction of earth-grading on contours and steps, and avoiding related environmental impacts and carbon dioxide emissions.

Agile operation is further enhanced by tracker self-powering that eliminates extensive power distribution, of what is remarkably

little consumption in all cases. Of the two self-powering types on the market, the auxiliary module type adds costs, and imposes latitude and seasonal variables in design, supply, installation, and operation.

Appropriate innovation has led to standard industrial-grade tracker products with features that can achieve certain yield-gain and/or agility benefits to cost-effectiveness. A successful tracker, and its supplier, will inherently solve more project challenges for the customer to help them find lower cost electricity and compel them to repeat business.

Tim Murphy is Communications Manager for Soltec, a manufacturer of PV tracking equipment with a 14-year-history, and global labor force of more than 750 people.

Soltec | soltec.com

DYNAPOWER

C O M P A N Y

Trusted Worldwide Since 1963

>400MWs

of energy storage inverters, DC converters and energy storage systems installed worldwide.

INCREASE PROJECT REVENUES

DC-COUPLED SOLAR PLUS STORAGE

Adding energy storage to a new or existing utility-scale solar installation with a Dynapower DC-DC converter can increase PV energy production through clipping recapture and low voltage harvest. Further adding to your bottom line, DC-coupled solar plus storage has a higher efficiency than AC-coupled storage and is eligible for valuable tax incentives for installation owners.

To learn more about how Dynapower's patent-pending line of DC-DC converters can increase project revenues and lower the installation costs of utility-scale solar plus storage, please visit our website to download the white paper.

To speak with a sales engineer today about modeling your project for energy storage, please call

1.877.215.0487

SAMPLE 20MW PV INSTALLATION WITHOUT DC-COUPLED STORAGE

Annual Lost Production: **1,923,256kWs**

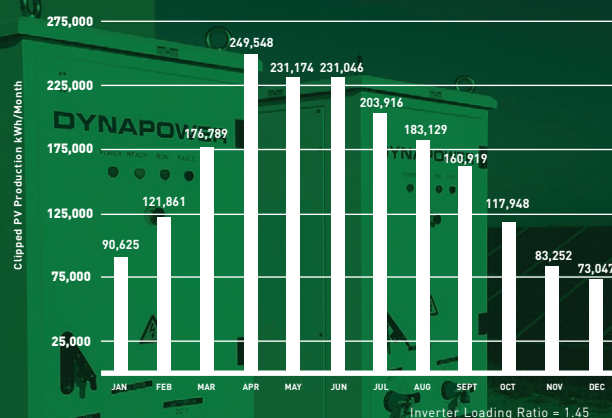

WWW.DYNAPOWER.COM/DC-DC



250kW to 3MW

A Wise Choice for Low Sun PV

by Rob Rallo

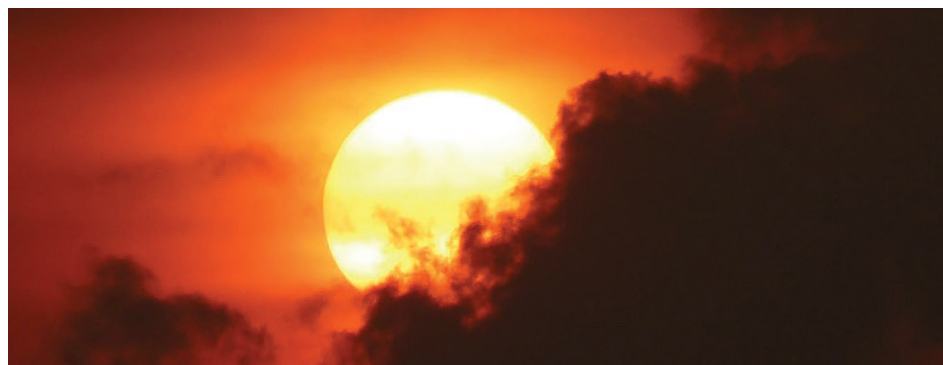

Solar-powered photovoltaic (PV) systems work great in most parts of the world; however, there are locations that get little or no sunlight for part of the year, rendering complications with using solar power. Fortunately, you can still use a solar-powered PV system in those locations by adding an alternate energy source, and making it a hybrid system.

Solar-powered PV systems have been a great and cost-effective solution for off-grid power generation for decades, but have struggled in northern climates like Alaska and Canada, where they get little to no sunlight during parts of the winter. Hybrid systems are the common solution to this problem. Hybrid systems use generators or wind turbines to provide power during the harshest winter months. In addition, 30-60 day battery banks are often used to increase reliability, and extend operation through the months with little or no sunlight.

All of these solutions have issues, which are further complicated by the extreme cold of their locations.

Derated for temperature, a large battery bank can be expensive, take a long time to recharge, and can be at a high risk of sulfation (due to the extended length of time at a low state of charge).

Wind generators rely on a variable resource that makes their energy contribution difficult to predict. Furthermore, they have rotating parts that require maintenance, which can be complicated by extreme cold.

STANDING SEAM ROOF ANCHOR

THE INDUSTRY'S LIGHTEST AND MOST UNIVERSAL FIT

1 DEVICE FITS OVER 500 DIFFERENT SEAMS

- Industry's lightest device at 4.5 lbs
- OSHA/ANSI 5,000 lbs tested
- Non-corrosive components
- Protects from falls in all directions
- Roof jack adapter plate available

863-703-4522

OR

TEXT SSRA TO 95577 FOR MORE INFO

Patent Number: US D629,679
www.standingseamroofanchor.com

Watch for more deals/messages, up to 4 messages per month. Data/Message Rates may apply. Purchase/Consent not required to participate. Reply HELP for help or reply STOP to stop.

Following is an example of a system designed to take advantage of the benefits of the SOFC in a solar hybrid system.

Problem: An application requires 80W 24V continuous load near Delta Junction, Alaska. As shown in the table to the right, Delta Junction enjoys very little sunlight in January and none in December with an average temperature of -23°C.

Climatic Data		Array Tilt		65 °
Month	Solar Insolation (kWh/m2)	Avg Temp (deg C)	Wind Velocity (m/s)	
Jan	0.60	-23.4	0.0	
Feb	3.19	-19.8	0.0	
Mar	4.65	-11.7	0.0	
Apr	5.10	-0.7	0.0	
May	5.08	9.2	0.0	
Jun	4.80	15.4	0.0	
Jul	4.60	16.9	0.0	
Aug	3.97	13.8	0.0	
Sep	3.19	7.5	0.0	
Oct	2.30	-3.8	0.0	
Nov	1.80	-16.3	0.0	
Dec	0.00	-21.4	0.0	
Avg	3.27	-2.9	0.0	
Max	5.10	16.9	0.0	
Min	0.00	-23.4	0.0	

Solution: Design and install a 1.9KW solar array, 777Ah battery bank, and 250W SOFC. As noted in the summary report below, the solar array contributes approximately 75% of the energy annually and the SOFC contributes the remaining 25%. Further, the SOFC consumes just 192 lbs. of propane for 15 cycles and 768 hours of annual operation. With such low annual fuel consumption, the needed fuel can be easily replenished during good weather providing additional savings via reduced fuel transportation cost.

PV Array:	PV Manufacturer / Model: Yingli 320P-35b Array Rating @ STC: 1.92 kWp @ 65 ° fixed tilt Average Array Output: 72.5 Ah / day	Quantity: 6
Wind Turbine:	WTG Manufacturer / Model: 0 WTG Rating: 0 kW @ 12.5 m/sec	0
Fuel Cell:	Manufacturer / Model: USSI P250i Fuel: LPG Quantity: 1 Total Rated Output: 250 W	Number of Cycles: 15 / year Run Time: 768 hrs / year Annual Duty Cycle: 8.8% Annual Fuel Use: 192 lbs
System Battery:	Manufacturer / Model: East Penn Mfg 8G8D System Voltage (Nom): 24 Volts DC Capacity (Amp-Hrs): 777 Ah @ 72 hr rate Days of Storage: 4.9 to 50% DOD Depth of Discharge (DOD): 50% Energy Storage: 9 kWh to 50%	Quantity: 6
Inverter:	Manufacturer / Model: 0.0 None Peak Rating: 0.0 KVA	
Annual Energy Contributions:	Average Annual PV: 75.6% Average Annual Wind: 0.0% Average Annual Utility: 0.0% Average Annual Fuel Cell: 24.4%	

Monthly Ah Contribution Summary

Month	# of days	% of Avg Load	Load Ah	Act PV Ah	Act Wind Ah	PV Contrib	Wind Contrib	Utility Contrib	Fuel Cell Contrib
Jan	31	100%	2,480	412	0	16.6%	0.0%	0.0%	83.4%
Feb	28	100%	2,240	1,978	0	88.3%	0.0%	0.0%	11.7%
Mar	31	100%	2,480	3,191	0	100.0%	0.0%	0.0%	0.0%
Apr	30	100%	2,400	3,387	0	100.0%	0.0%	0.0%	0.0%
May	31	100%	2,480	3,487	0	100.0%	0.0%	0.0%	0.0%
Jun	30	100%	2,400	3,188	0	100.0%	0.0%	0.0%	0.0%
Jul	31	100%	2,480	3,157	0	100.0%	0.0%	0.0%	0.0%
Aug	31	100%	2,480	2,725	0	100.0%	0.0%	0.0%	0.0%
Sep	30	100%	2,400	2,119	0	88.3%	0.0%	0.0%	11.7%
Oct	31	100%	2,480	1,579	0	63.7%	0.0%	0.0%	36.3%
Nov	30	100%	2,400	1,196	0	49.8%	0.0%	0.0%	50.2%
Dec	31	100%	2,480	0	0	0.0%	0.0%	0.0%	100.0%
Total	365		29,200						
Avg	30	100%	2,433			75.6%	0.0%	0.0%	24.4%

A more detailed analysis in the table below shows the energy contribution month by month. The load is supported 100% by the solar array from March through August with the fuel cell assisting from September to February with 100% contribution in December.

Even in the most remote locations and the harshest environments, solar can still be used to power load equipment when coupled with the proper supplemental energy source in a hybrid system.



Rail-less solar mounting system

Magerack has improved its rail-less solar mounting products and now adds a new rail-less solar mounting system to its product line, MageMount II. MageMount II Rail-less Solar Mounting System is now compatible with most solar modules with regular module frames. Similar to previous system MageMount, it separates roof attachments from module connecting components. Roof attachments are only used to attach solar modules to the roof and are installed wherever necessary to reduce the number of roof penetrations. Module connectors are only used to connect adjacent solar modules. The improved module connectors can connect two solar modules without roof attachment support and doesn't require any special module frame. The new module brackets act as attaching devices to attach any roof attachments to solar modules. The system is certified in compliance with UL 2703 and Class 'A' fire rating and comes with roof attachments for all roof types.

Magerack | www.magerack.com

Generators need to be hardened for extreme cold. They may require block heaters and other accessories that decrease overall efficiency, and add to the load on the PV system. Efficiency is further reduced by frequent exercise cycles.

Thermal Electric Generators (TEGs) are another potential hybrid power source. However, TEGs are extremely inefficient and cannot be cycled; they must be turned on in the fall, and turned off in the spring.

Fuel cells are another great option. However, not all fuel cells are the same. PEM fuel cells do not work well in cold climates; if their membranes freeze, they can be damaged. They need to be exercised in order to keep their membranes from drying out. Getting hydrogen fuel to a remote site can also be a challenge.

Solid Oxide Fuel Cells (SOFCs), on the other hand, are a nearly perfect solution.

SOFCs can operate in ambient temperatures as low as -40°C, and storage temperatures as low as -65°C. They can sit in standby for months, or years. They only consume 0.05W in standby, and can be cycled. SOFCs are also very efficient - consuming as little as 0.25 lbs. of LPG/hr. for 250W of electrical energy.

SOFCs have been added to trailed mounted solar systems to extend their runtime, and to stand-alone solar systems with critical loads. Their fuel efficiency, low standby power consumption, and lack of required exercise cycles, make them a great complement to solar.

Rob Rallo is a Senior Engineer at SunWize Power & Battery. He has been in the solar industry for over 28 years, focused on off-grid power solutions, and is currently working with IEEE to update the industry standards regarding off-grid power systems. SunWize offers a range of on the shelf and fully custom stand-alone PV, hybrid, and battery-backup power systems, as well as a full complement of battery and control cabinets, and quality power system parts.

SunWize Power & Battery
www.sunwize.com

MICROFLASHING™

HOW IT WORKS



Microflashing™, comprised of a Stainless Steel backed EPDM washer, is installed on top of the roofing - no removing nails or lifting shingles



The collar on the patented QuickBOLT compresses and concaves the Microflashing™ to create a watertight seal



Use manufacturer's approved sealant on the underside of the Microflashing™ to help it completely adhere to the roofing surface



This is our Microflashing™ after being installed for only 3 weeks. As you can see, the asphalt from the roof itself has bonded with the EPDM; forming a leak proof seal.

The only product on the market that doesn't just divert water, but also seals the penetration.

Try it for yourself today!

ORDER ONLINE
(844) 671-6045
www.solarroofhook.com



VISIT US AT SPI 2018
BOOTH# 286



Single-pole high-current connector

Stäubli Electrical Connectors has launched the new 16BL single-pole high-current connector, which was specially designed with optimized safety functions and increased flexibility specifically for (emergency) power supplies and industrial applications. The 16BL allows safe, intuitive use and reliable power transmission under extreme environmental conditions, even in a temperature range from 40°F to 248°F (-40°C to 120°C). The new 16BL connector system is designed for high power up to 630A. The components are robust and can be used easily and safely, even under the most adverse conditions of use (IP65, IP68, and IP69 degree of protection; salt-spray resistant). The new 45° bayonet locking system, as well as the crimp and reusable AxiClamp cable connections, ensure a reliable connection. The color and mechanical coding allows quick, intuitive identification and connection in the field with no risk of confusion. The micro-switch is integrated into the flush-mounted socket signals the connection is plugged in and can also be integrated into a safety circuit for machine enabling, fulfilling IEC 61984. Besides high numbers of mating cycles (up to 5,000), the tried and tested MULTILAM technology guarantees consistently high contact quality with constantly low contact resistance throughout the entire lifespan.

Stäubli Electrical Connectors | www.staubli.com



Easy and efficient PV system design

The latest version of the design software PV*SOL premium 2018 makes the design of photovoltaic systems even easier and more efficient. For the input of object data, 3D models in different file formats can now be imported into the software via a new interface. This makes it possible to import realistic and detailed 3D objects created with photos taken from different perspectives. This adds another tool to the current platform which allows the importing of floor plans, cadastral maps, and screenshots from web-based satellite maps directly into the 3D visualization, and thus integrating them to scale into a project. Flexibility has been increased with the subsequent configuration of the modules, which are automatically placed on an object. The new polystringing configuration allows completely different strings to be connected in parallel or series to an MPP tracker. This is required to connect an east-west roof parallel to one MPP tracker. Even different modules in a string can now be interconnected. Modules with different orientations can now also be connected in one string via the integration of power optimizers. Other useful additions for the optimization of a system are the output of the I-V characteristics for each time step of the simulation, as well as an energy flow diagram representing the overall system including the battery system, consumers, and also an electric vehicle. PV*SOL is a valuable tool for sizing a PV system correctly, as well as for determining profitability. A dimensioning aid for sizing the battery storage carries out the calculation of the battery for the user, thus facilitating project design. Both PV*SOL and PV*SOL premium are available in German, English, French, Italian, Polish, Portuguese and Spanish.

Valentin Software | www.valentin-software.com



Speed, efficiency, and safety in a solar canopy

Quest Renewables' QuadPod double cantilever is the company's newest introduction to the carport market. With QuadPod, local EPCs can assemble and construct systems themselves, saving on markup of the foundations and of the assembly and construction. The construction is straight forward and repeatable, and most EPCs source foundation, construction, and electrical labor locally, enabling them to extract the most value from their projects. The double cantilever has a standard 14x13 configuration for areas below 30psf of snow and a 12x12 configuration for areas with 30psf of snow and above. With just 3 foundations per 100kW, the QuadPod double cantilever can easily be applied to any parking lot configuration regardless of parking spot width or drive aisle dimensions. 90% of QuadPod's construction takes place on the ground, inclusive of module and inverter wiring. After the on the ground assembly, electrical and lighting, the canopies are lifted by crane for final installation, minimizing overhead work and optimizing worksite safety. The mechanical and electrical workers get a safe construction environment, and the incremental cost of the crane is more than made up by the efficiency gained. Short on-site time reduces construction management costs, increases throughput, and limits disruption to parking lot operations.

Quest Renewables
www.questrenewables.com

POWER.PLANT.



CROWN
RENEWABLE POWER
BATTERIES





When you're going off-grid you become the power plant.

And when you need a battery to provide your power needs, depend on the best: **Crown Battery**. Thick energy-dense plates. Heavy-duty construction. More active lead materials. Proven low-maintenance performance. It all adds up to one **World Class Battery. Crown.**

CONTACT US FOR DETAILS: +1.419.334.7181 / commercial@crownbattery.com / www.crownbattery.com

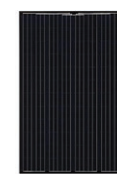

High efficiency PV modules

Panasonic Eco Solutions North America's HIT high-efficiency PV modules with innovative silicon heterojunction technology, the HIT N315K and N320K, are Panasonic's new line of all-black solar panels which have a temperature coefficient of -0.258%. Their N335 and N330 solar panels are high-efficiency solar modules with a 40mm frame. These solar modules are manufactured with "N" type cells, which reduce the annual performance degradation from 0.70% to 0.26% when compared to conventional solar panels.

Panasonic Eco Solutions North America
www.business.panasonic.com



Ultra-wide and ultra-high input voltage series

MORNSUN recently introduced 200W PV200-29Bxx series which has an input voltage of 300-1500VDC to further meet customer demand of ultra-wide and ultra-high input voltage in new energy systems. They can be widely used in photovoltaic power generation, energy storage BMS, high voltage inverter, and other industries. PV200-29Bxx series also provides power up to 200W to meet higher demands for high-power power supply in ultra-wide and ultra-high input voltage application, and high efficiency up to 87%, low power consumption and more energy-saving. PV200-29Bxx series have input under-voltage protection to avoid frequent restart of system to maintain the system's stability. Offering MTBF over 300,000h, they have reverse input voltage protection, output short circuit, over-current and over-voltage protection. These protections greatly reduce the probability of failure of the power supply itself while greatly enhance the safety performance of the module power supply and the load under abnormal working conditions. PV200-29Bxx series meet UL174, CSA-C22.2 No.107.1, and EN62109 standards (pending) with a certified voltage of 1500VDC. The series offers isolation voltage up to 4000VAC and high reliability, to effectively protect the safety of the system.

MORNSUN | www.mornsunamerica.com



Lowering energy bills in disadvantaged communities nationwide

GRID Alternatives announced the rebranding of its solar installation program. The new Energy for All Program will continue to help low-income households, multifamily housing providers, and utility partners across the country reduce electricity costs and generate community wealth with clean, renewable solar energy. The Energy for All name is a reflection of GRID's commitment to a transition to clean, renewable energy that includes and benefits everyone.

GRID Alternatives
www.gridalternatives.org



Integrated, all-in-one solar street lights

Enkonn Solar is a manufacturer of All-in-One solar streetlights and integrated solar garden lights that are widely used in government and municipal projects. The All-in-One solar street lights from Enkonn Solar boast advanced integrated design. The new-generation solar light is a compact light with all parts including a motion sensor, LED, solar panel, and battery into one single unit. Backed by the MPPT solar charge controller, the All-in-One street lights offer features including: durable integrated die-casting aluminum alloy case housing; 30 seconds of bright when people pass through; simple installation with no wiring required; 100% solar powered and no energy bills; integrated lighting structure assures easy transportation. Enkonn Solar assures assistance with the installation of its solar power streetlights as well.

Enkonn Solar | www.enkonn-solar.com





Calibrating to a higher standard

Solar Radiometer Calibration Services

ISO-CAL provides fast, reliable, ISO/IEC 17025 and ANSI/NCSL Z540 accredited solar radiometer calibration services: WRR, WISG and/or NIST traceable.

Equipped to calibrate any pyranometer or pyrhelimeter model type, ISO-CAL offers both indoor and outdoor Primary or Secondary reference calibration services in accordance with all ISO and ASTM calibration standards.

Supported sensor types:

- ✔ Pyranometers
- ✔ Net Radiometers
- ✔ Pyrhelimeters
- ✔ PAR Sensors
- ✔ Pyrgeometers
- ✔ LUX Sensors
- ✔ UV Sensors
- ✔ Spectroradiometers







480-336-8133

info@isocalnorthamerica.com
www.isocalnorthamerica.com

SR30 | Digital Secondary Standard Pyranometer

Join the evolution...



ev·o·lu·tion
/ ,evə'looSH(ə)n/

noun
The gradual development of something, especially from a simple to a more complex form.

When it comes to superior performance, even Darwin would agree the latest SR30 pyranometer from Hukseflux is the natural selection.

SR30 pyranometer employs an internal, low power, maintenance-free ventilation system with heating, rendering larger higher power/ high-maintenance external ventilators obsolete. The SR30 is locally supported in the U.S. and backed by a 5-year warranty.

- Superior measurement accuracy
- Highest data availability
- Low cost of ownership
- Most value added features standard
- Performance validated (test data included)
- Compliant with latest ASTM & IEC standards

New



Low-power internal ventilation with heating via digital control over RS485 / Modbus (patent pending)

Internal ventilation port
Easy-view bubble level



631-251-6963

info@HuksefluxUSA.com | www.Hukseflux.com



Stable and flexible tracking system

Schletter Group's new single-axis tracking system not only allows a ground cover ratio due to its patent pending locking mechanism and 4m width, it also has the same level of stability as a fixed mounting system. The drive concept requires no hydraulic dampers and completely avoids the dangerous 'galloping effect' under wind loads. This Schletter system works with a self-locking mechanism. Each post is equipped with a mechanical locking element which automatically locks as soon as the row has stopped moving. This drive system eliminates wind vibrations over the entire row. Therefore the system, while at rest, has the properties and durability of a fixed mounting system and is designed to withstand wind speeds of up to 260km per hour. The tracker has a rotational range of $\pm 60^\circ$ and tracks the sun astronomically. Each row can be up to 120m long and is driven by one centrally located motor. Each row is 4m wide and can hold two panels vertically or four horizontally. This allows operators to make optimal use of the land and a ground cover ratio of more than 50% can be achieved. The motor and the control systems are powered by a dedicated PV panel in each row with a battery pack, ensuring reliability of operation. The system is controlled through wireless technology which eliminates wiring for both power supply and communication. The upper sub-assembly comes pre-mounted to the motor unit, so installing the system is quick and safe. The motor and control system are plug and play. The system is manufactured mostly from galvanised steel and can stand either on pile-driven or concrete foundations. Furthermore, the system is able to compensate slopes of up to 10° . To make maintenance and servicing easy, mechanical connections between the rows have been avoided. This allows unhampered vehicle access between the rows.

The Schletter Group | www.schletter-group.com



Streamlining PV design for a value-driven solution

SolarEdge Technologies, Inc. is launching its new Designer tool to enable faster, easier planning of solar energy system designs. The new web-based tool with an intuitive graphical interface helps installers lower PV design costs and increase conversion rates by creating compelling customer proposals. The free Designer tool is part of SolarEdge's comprehensive vision to support the entire PV process, including design, quotation, installation, and monitoring in one, end-to-end, cloud-based platform. Developed with SolarEdge's expertise in PV software, and using input from SolarEdge's global community of PV professionals, Designer streamlines SolarEdge system design to create a value-driven solution. Saving design time and costs, Designer uses satellite imagery and provides instant validation of a site's design. The tool also simplifies the electrical design process with product recommendations and a Bill of Materials report. By creating attractive and informative homeowner offers, which include intuitive 3D site modeling and monthly energy simulations, SolarEdge's Designer supports the sales process for PV installers. Now available around the world, Designer is hosted in the cloud with access from any Mac or PC, enables multi-user access, and offers seamless integration with the SolarEdge monitoring platform for quick creation of site layouts.

SolarEdge | www.solaredge.com



High range time-of-flight sensor

The VL53L1X time-of-flight sensor from STMicroelectronics extends the detection range of ST's FlightSense technology to four meters, bringing high-accuracy, low-power distance measurement, and proximity detection to an even wider variety of applications. FlightSense sensors directly measure distance to the object based on the time for emitted photons to be reflected, enabling accurate distance-ranging regardless of the object's surface characteristics. With low power consumption and fast ranging performance, the VL53L1X is ideal for mobile robotics for wall following, cliff detection, collision avoidance, and hover/landing assistance for drones or unmanned aerial vehicles (UAVs). The power-saving presence-detection mode enables auto-sleep/wake-on-approach use cases for PCs, notebooks, and IoT devices, in addition to camera auto-focus assist, and gesture recognition. The fully integrated and miniaturized VL53L1X measures 4.9mm x 2.5mm x 1.56mm, allowing use even where space is very limited. It is also pin-compatible with its predecessor, the VL53L0X, allowing easy upgrading of existing products. The compact package contains the laser driver and emitter as well as the Single-Photon Avalanche Diode (SPAD) light receiver that gives ST's FlightSense sensors their unrivaled ranging speed and reliability. Furthermore, the 940nm emitter, operating in the non-visible spectrum, eliminates distracting light emission, and can be hidden behind a protective window without impairing measurement performance.

STMicroelectronics International

www.st.com

- Commercial flat/sloped roof and commercial ground mount solutions
- Faster Assembly
- Complete Engineering Services
- UL2703 tested solutions
- Servicing USA, Canada, Mexico & the Caribbean

1.844.860.6722
SALES@POLARRACKING.COM
WWW.POLARRACKING.COM



Solar LED light tower rental for remote locations

Larson Electronics is offering an energy-efficient solar LED light tower for rental in remote locations, such as emergency operations, security checkpoints, construction, concerts, and military camp sites. The solar LED light mast is equipped with four, 150-watt LED lamps, supported by a 10.7kW water-cooled diesel generator, eight, 300W solar panels, and ten, 105Ah AGM batteries. The RNT-SPLT-2.4K-LM30-FM-20X105AH-4X30L-10KW-CPR is an effective solution for sustainable illumination in locations without direct access to a local grid. The aluminum light mast with a steel canopy can be elevated from 8ft up to 29.5ft. Equipped with six stages, the tower is adjustable in 360°, and provides resistance from 40mph winds. A total of eight, 300W solar panels can be used to harvest sunlight, while storing power in ten, 105Ah AGM batteries (1,200Ah total/600Ah usable). An integrated compass offers guidance, when positioning the solar panels for maximum exposure to sunlight. Charge time for the 24V DC system is 9.5 hours, with a runtime of 30 hours and an expected lifespan of 5-7 years. Power storage management is facilitated by a 48V DC Morningstar TS-MPPT-600V controller. The entire solar LED light tower is skid mounted and secured on a trailer base. Deployment may be completed on the ground without the single-axle trailer. The trailer lights are US DOT compliant and four 1000lb outriggers offer support on rugged or uneven terrain. For grid configurations, multiple solar LED light towers can be connected simultaneously.

Larson Electronics LLC | www.larsonelectronics.com

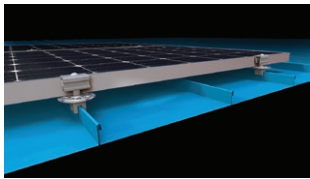

Ease of installation and time saving improvements

S-5! has released PV Kit 2.0 EdgeGrab and PV Kit 2.0 MidGrab, offering solar panel installers significant improvements and easier installation. Among the improvements to the new PV Kit 2.0: only one tool needed for installation; preassembled components save time and money; installs with module, reducing lay-out time; single-piece EdgeGrab installs with ease, versatile: same kit for most modules; creates a 1-inch gap between modules, allowing load reduction per ASCE-7; improved disk design works with all S-5! clamps and exposed-fastened brackets; and UL 2703 Listed (Pending). These enhancements make the PV Kit 2.0 a cost-effective PV mounting solution for installers, design professionals and building owners. **S-5!** | www.S-5.com



90-degree metal edge clip

On many utility solar farms, it is common to skip string, or leapfrog, module wires to reduce BOM costs. Typically, the wire is barely long enough to connect the module leads. This clip's 90-degree configuration eliminates a bend in each cable, leaving more wire available for a secure connection. The clip's design, with its large push point, is especially easy on installers' thumbs. Combined with low insertion force, no tools are needed to mount the clip. Yet, it features excellent extraction force on any panel edge, particularly along low-profile solar module frames and module interface brackets. Being UL Listed and Recognized streamlines the inspection process, critical in an industry where lost time and part replacement costs escalate exponentially. This configuration joins a family of heavy duty and low-profile metal and plastic "Solar E-Clips."

HellermannTyton
www.hellermann.tyton.com



Flexibility in cable and wire bundling

SolarRoofHook is excited to announce the launch of the new Quick Ratchet Clamp, designed to work with their QuickBOLT with Microflashing Asphalt Mounting System. The Quick Ratchet Clamp is used to secure conduit on to the solar array. The adjustability of the ratchet allows installers to attach hard or soft bundles with a wide range of diameters. This new addition to the SolarRoofHook line saves the installer time and money by easily attaching to the QuickBOLT with no extra tools or hardware. The Quick Ratchet Clamp is installed by simply tightening it onto the QuickBOLT with the provided flange nut.

SolarRoofHook | www.solarroofhook.com



Our dual-axis trackers follow the sun to produce up to 45% more energy than fixed solar. Now the new Gen 4 solar tracker makes it even easier!

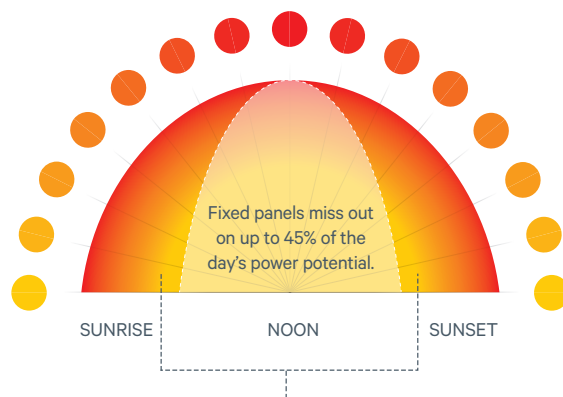

AllEarth Solar Trackers follow the sun's energy-producing rays throughout the entire day.

Maximized Net Metering

The most energy produced for AC watts installed. Maximize your net metering production and value.

Improved Accessibility

The inverter can now be mounted lower on the mast of the tracker, or separated from the structure. Making wiring and maintenance a breeze!

Improved System Monitoring

Expanded communication options: Tracker is now WiFi, cellular and SD card enabled to check the power generation and mode status with ease.

Self Powered Smart Design

The dual-axis tracker will keep following the sun, even when the grid is down: The tracker uses energy from the panels so it will maintain the correct mode status.

Learn more at allearthrenewables.com/partners



AllEarth Solar is a division of AllEarth Renewables, Inc. | allearthrenewables.com | 802.872.9600

ALLEARTH and the ALLEARTH SOLAR logo are trademarks of AllEarth Renewables, Inc. © 2018 AllEarth Renewables, Inc. All Rights Reserved.



Elevated monitoring and control

SMA is investing in efforts to digitize commercial energy management and bring greater energy independence to customers. The company has introduced a new, future-proof generation of monitoring and control solutions with the Data Manager M. In combination with Sunny Portal powered by ennexOS, an IoT platform that manages all energy generation sources and data on a single platform, the Data Manager M is a solution for commercial system owners and operators alike. It optimizes communication, monitoring, and control of decentralized PV systems for up to 50 devices, and with a new, highly efficient user interface, the Data Manager M is easy to set up and commission. The Data Manager M, which replaces SMA's Cluster Controller, is a flexible and expandable solution equipped to enable business models of the future energy market. With intuitive setup functions for the Data Manager M and inverter, commissioning time and associated labor is significantly reduced. And, with ennexOS, system and inverter parameters can be changed remotely via Sunny Portal, further reducing costs.

The SMA Group | www.sma-america.com



Helping customers navigate the financing process

Designed to help businesses, organizations, municipalities, educational institutions, and others navigate the often complicated solar financing landscape, Standard Solar, Inc. released a free eBook, "Commercial Solar Financing - The Definitive Guide." According to GTM's new report, Commercial Solar Consumer Finance Trends, third-party ownership in commercial solar has been increasing since 2015, driven primarily by the intense growth in community solar. Community solar accounted for almost 20% of commercial installations in 2017, 99% of which were third-party owned. There are multiple factors for each commercial customer that influence the financing decision. In "Commercial Solar Financing - The Definitive Guide," Standard Solar's experts present the complicated financing subject in terms everyone can understand, giving potential solar owners the information they need to evaluate their potential financing partner to make sure success is attainable. The book addresses such crucial questions as: Why financing in the commercial solar segment has lagged; The different vehicles companies can use to build financing packages (from PPAs, leasing, loans and beyond) and; Why in-house financing is quickly becoming the preferred commercial solar financing model.

Standard Solar, Inc. | www.standardsolar.com



One-size-fits-all racking solution

The new EcoX Universal Rail-Less Racking System fits any module thickness from 32mm to 46mm using a single size for each core component. EcoX Universal builds on Ecolibrium Solar's EcoX Rail-Less Racking, with more than 500MW installed. The new single-size core components simplify solar installation even further, providing quick, pre-assembled parts that streamline the install process. Installers no longer need multiple racking SKUs to handle different module frame thicknesses, eliminating excessive inventory and streamlining transportation and storage. Project speed is accelerated due to 33% fewer penetrations than a rail-based system, the elimination of awkward rails, easy wire management, and the elimination of rough inspections. An extensive list of UL2703 certified modules makes the inspection process go smoothly and quickly. EcoX Universal works on all roof types: composite, tile, metal, and low slope.

Ecolibrium Solar
www.ecolibriumsolar.com

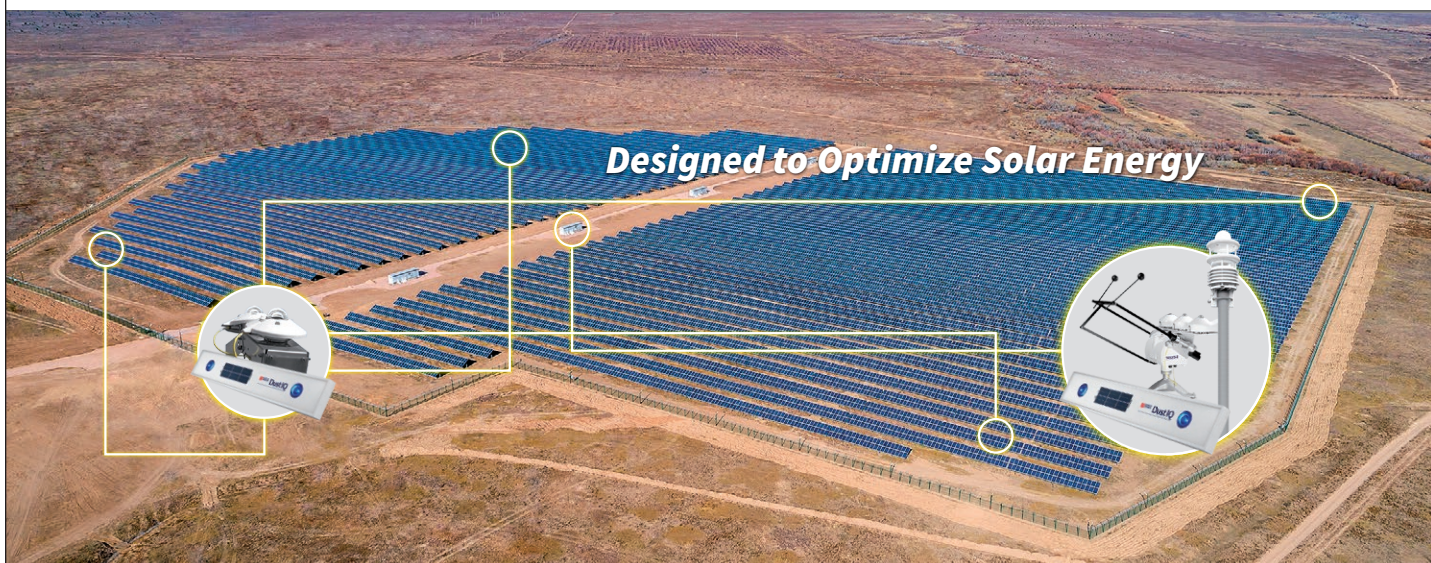

The amount of solar radiation reaching your power plant cannot be changed; however, you can make the most of it by choosing high quality equipment. Not only by selecting efficient generating technologies, but by installing the industry's best instruments to monitor the environmental parameters affecting your solar energy project performance.

Whether it is to optimize yield, manage your assets, make investment decisions, schedule plant maintenance or to forecast the energy output reliably, we offer the instruments you need. From Kipp & Zonen smart pyranometers and Lufft weather stations, to the unique new DustIQ for continuous monitoring of module soiling, we have it all.

www.kippzonen.com/energy



Solar thermal system design and simulation

The new version T*SOL 2018 now includes features such as: more than 3,650 flat plate and evacuated tube collectors, and 1,550 boilers and auxiliary heaters can be accessed, storage tanks can now also be defined and saved by the user, in addition to collectors and boilers. To optimize the solar thermal system, each component (collector, pipes, storage tank, boiler, etc.) can be parameterized individually. And with the help of the parameter variation, it is also possible to perform several simulations simultaneously, e.g. to automatically dimension the collector area and storage tank volume. A variety of tools are available for the evaluation of the results. The project report provides detailed simulation outputs, and graphs which can be created with a wide range of temperature and energy data for more in-depth analysis.

Valentin Software GmbH
www.valentin-software.com



Advanced observation tool with cloud monitoring

Designed to withstand all weather conditions, the ASI-16 All Sky Imager features a digital camera and fish-eye optics with a 180° field of view assembled under a robust coated quartz dome, avoiding sensor degradation due to direct exposure to the sun and allowing the automated acquisition of high dynamic range (HDR) images of the hemispherical sky. The standard ASI-16 Sky Imager is capable of operating under harsh environments from temperatures as low as -40°F up to 122°F, with an integrated ventilation and heating system, which also prevents condensation on the dome surface and promote the fast removal of raindrops and snow. Furthermore, the imager is powered over ethernet (POE), with a durable and waterproof cable. The users have full control of the imager to perform settings, data acquisition, visualization, and storage, with a web browser-based manager with live video stream and network storage. The Sky imager is complemented with the Find Clouds software, in which the images acquired with can be processed to classify cloudiness. Using different algorithms to calculate cloudiness, the cloud analysis software, allows the calculation of the sun position in the image as well as to run algorithms such as the blue/red and blue/green channels ratio (BRBG), and the cloud detection and opacity classification (CDOC), to quantify cloudiness on the image set.

EKO USA | www.eko-usa.com



Expanded AC combiner product line

SolarBOS announces a broader line of AC Combiners to compliment all string inverter applications. SolarBOS AC Combiners are easily customizable for wide range of projects. Custom output busses allow direct and convenient connection to a transformer. Other options include integrated input or output disconnects, auxiliary breakers, integrated SCADA monitoring components, convenience receptacles, pre-terminated custom length input conductors, and surge protection. Key highlights of SolarBOS AC Combiners include: bi-directional fuses, custom output bussing, outdoor rated NEMA-4 enclosures, high interrupt rating, reduced PPE requirements, reduced maintenance, 100% operation and reliability, and OCPD coordination.

SolarBOS | www.solarbos.com/AC_Solutions



Solar training

Interplay Learning's Solar Basics 101 course is now live and ready to help new installers, sales team members, customer service reps, and students learning about solar. The basics courses will continue with additional 102 - 105 level courses as well as 201 - 205 advanced level courses. These core solar courses combine with Interplay Solar's simulation based training to provide a comprehensive solar training program.

Interplay Learning

www.interplaylearning.com

Panasonic

STRIVE FOR GREATNESS

Every few decades a big opportunity emerges for small businesses. Today, that opportunity is solar energy. But to capitalize as fast as possible, it's critical you choose the right partner. Every solar milestone we've achieved over the last 40 years has prepared us to help you seize this moment. Ready?

Let's take your business to profitable new levels together.

- ✋
A partner you can bank on
 Comprehensive product, sales and marketing support from one of America's most trusted brands. 100 years in business and growing.
- ♻️
Solar power performance
 When you install Panasonic HIT® solar panels, you'll provide homeowners with what we believe are the most efficient solar modules available today.
- 💡
Solar industry pioneer
 With 43 years' experience in the solar industry, we've been pioneering solar power since the green revolution began.
- ✅
A warranty as strong as the company backing it
 Stand behind your work confidently with our complete 25-year TripleGuard warranty. Backed by the financial strength and stability of Panasonic.





na.panasonic.com/us/solarpanels



Plug-and-play power system

Phocos' new Solar Home System (SHS) kits offer high efficiency LED lighting combined with energy dense lithium storage. Phocos SHS kits are compact, portable, plug-and-play turnkey solutions that supply off-grid power for efficient DC lighting to mobile device charging. These affordable kits provide clean and reliable autonomous power, ideal for rural applications. Each kit includes a solar panel (5W, 10W or 20W), a lithium-iron phosphate battery (LFP battery), MPPT charge controller, 3 DC lamps, and the appropriate cables for easy set up.

Phocos | www.phocos.com

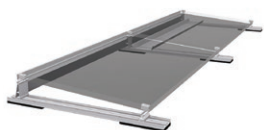

New generation mounting system for flat roofs

The Schletter Group's 2018 FixGrid kit system combines the benefits of the FixGrid and AluGrid systems, capable of withstanding high wind and snow loads, making it suitable for locations exposed to extreme weather. The FixGrid 2018 leaves the factory with a newly developed swivel connector that can be put together without tools, and its building protection mats come pre-attached to the kits' base plates, which reduces the assembly and mounting time, and costs per kWh of installed PV capacity. Windsafe plates and ballast tubs are only used where they are needed for technical reasons. Windsafe plates, including an integrated ballast slot for the south-facing variant, allow adequate ballasting for places with higher wind loads. This makes it possible to use FixGrid 2018 almost everywhere. The ballast blocks can be applied to continuous beams, ballast tubs, and Windsafe panels. Almost all components are from Schletter's standard range and are also part of other assemblies. The FixGrid 2018 comes in several kit variants, covering the majority of applications: for east-west-oriented arrays, kits are offered for two or three pairs of solar panels. For elevated south-facing solutions, the system is available for two or three rows of panels. The rows are maintained as a single unit, and any configuration of panels can be realized. The free SchletterConfigurator software automatically selects the ideal kits and handles structural analysis for the system, generates a ballasting plan, and a parts list. The systems are shipped out including a professional structural analysis, system documentation, and assembly instructions.

The Schletter Group | www.schletter-group.com

Software-based educational tool

Rocky Mountain Institute's (RMI's) Business Renewables Center (BRC) launched its Buyers Roadmap, a software-based educational platform to help buyers of renewable energy better understand the transaction process for procuring wind and solar power. The Buyers Roadmap educates non-utility energy buyers through a standardized process to plan and execute a power purchase agreement (PPA) for renewable power. The Buyers Roadmap includes detailed instruction and advice to fit a range of buyer needs, including determining energy load and company goals, running a request for proposal (RFP) process, and ensuring follow up after the commercial operation date. The BRC's Buyers Roadmap also includes a number of deep-dive guides on topics such as accounting, risks associated with long-term PPAs, and an RFP template to streamline the request for proposal process with proven best practices. The Buyers Roadmap was developed as part of BRC's digital Learn|Analyze|Opportunities product suite that includes the Market Analysis Platform (MAP) for identifying project value and the BRC Marketplace, which connects corporate buyers and service providers with available renewable energy projects and project developers.

Rocky Mountain Institute | www.rmi.org



Turnkey building block for large-scale PV plants

SMA's Utility Power Rack 5000/5500 is a highly integrated, turnkey solution offering up to 40% integration cost savings over alternative solutions. It is completely pre-assembled for easy set up and commissioning, reducing time-consuming labor processes in the field and minimizing installation risk. Compatible with both Sunny Central and Sunny Central Storage 2500-EV(-US) and 2750-EV(-US) inverters, the Utility Power Rack is a building block for large-scale PV plants. It offers true 1,500V technology, which means more reliable stack design and long-term, trouble-free operation. Offering convenience and flexibility, the Utility Power Rack can be used with multiple storage options from SMA, providing a standardized process for integrators who are working on both PV and storage projects. It also includes a multitude of configurable options to meet the needs of any plant.

The SMA Group | www.SMA-America.com



Residential solar monitoring

The all NEW Solar-Log 50 Gateway, a compact, advanced residential solar monitoring solution, is now available in the U.S. The Solar-Log 50 is a solution for the price-sensitive residential solar market segment, for plants up to 15kW. Its modular hardware and software pricing means users only pay for the features they need. This gateway is designed to be used in combination with the Solar-Log WEB Enerest portal and provides reliable PV yield and plant performance data through inverter direct communication. The Solar-Log aggregates data from over 100 inverter brands through RS485 or Ethernet connection. Data is transferred via wired internet connection (required) and visualized on the Solar-Log WEB Enerest portal. The compact, din rail mountable hardware can be installed in as little as 10 minutes. The included Solar-Log WEB Enerest M monitoring subscription is a simplified solution for homeowners who want to monitor their plants themselves. The monitoring subscription can be upgraded, for a subscription fee, to the L or XL package at any time, for installers offering O&M service contracts to their customers. The Solar-Log WEB Enerest processes the recorded data, making numerous reports possible, and has analysis tools for the efficient use of solar energy. The user is continuously informed about plant performance and potential malfunctions. Add-on functions for the Solar-Log 50 Gateway are available through corresponding licenses, and include feed-in management, increased plant size compatibility, and integration of additional components.

Solar Data Systems, Inc. | www.solar-log-america.com



Mobile fume extraction with automatic filter cleaning

Lincoln Electric's new Mobiflex 400-MS is a self-cleaning welding fume extraction and filtration system designed to extend filter life and reduce maintenance for users. For smaller manufacturing facilities, this system provides light to medium duty welding fume extraction in variable locations. The RotaPulse automatic filter cleaning system and large filter capacity enable users to maintain operation effectiveness and decrease downtime with less filter changes. The filter status indicator monitors the amount of particulate in the filter cartridge to alert the user when it is time for replacement. The internal spark arrester—a safety measurement functioning as a pre-filter for larger sized particulate—prevents sparks from reaching the filter. The system provides automatic on and off operation in models having extraction arms equipped with an arc sensor and lamp kit. The Mobiflex 400-MS base unit includes a plastic housing, two-foot flexible hose, and choice of MERV 14 or MERV 16-rated filter. A 10ft. or 13ft. extraction arm, with or without the factory-installed arc sensor/lamp kit, or a hose/hood set is required to complete the system. The fume extraction arms are flexible and lightweight, while remaining rugged, reliable, and dent and scratch resistant, enabling easy transportation. Lastly, the arms come equipped with a 360° rotatable hood for optimal positioning.

Lincoln Electric

www.lincolnelectric.com



Intelligent residential solar inverter series

ABB's single-phase inverter family is smart, optimal, and code compliant for an efficient solution in residential solar installations. The new UNO-DM-PLUS-US series is now available in five power ratings, from 3.3 to 6.0kW. These solar inverters have a compact design, delivering high performance with excellent power density enabling maximum energy production. They are designed with digital intelligence and technical sophistication which optimizes the performance of residential PV installations. The UNO-DM-PLUS-US series is Rule 21 phase 2/UL1741-SA and is SunSpec Certified. The UNO-DM-PLUS-US series is compatible with ABB's string-level Rapid Shutdown. The ABB RSD 2.0 unit is available in single and dual channel connections and quickly installs to the panel. This flexible inverter design comes with embedded connectivity and efficient communication SunSpec Protocol, which enables the UNO-DM-PLUS-US to be easily integrated within any current or future device for smart building automation, smart grid integration, and with third party monitoring and control systems. The UNO-DM-PLUS-US also comes with remote Over the Air (OTA) firmware upgrade for inverter and components. Once the inverter is installed, operators can turn to a smartphone to commission the unit via a simple, built-in web user interface. This enables them to gain access to features such as advanced inverter configuration settings and Aurora Manager, which facilitates OTA firmware updates (remote software up-dates).

ABB | www.abb.com



Robust series of compact AC filter capacitors

TDK Corporation announced a new series of EPCOS MKP AC capacitors for filter applications. The B33331V* series capacitors are designed for a rated voltage of 460 VRMS, corresponding to a peak voltage of 650V, and cover a capacitance range from 2 µF to 50 µF. Both the cans and the tops are constructed of aluminum, making the overall design particularly robust. Despite this, the dimensions – depending on the type – range from just 30mm x 55mm to 50mm x 100mm). The reliability of the new capacitors, even under harsh conditions, has been verified by a temperature, humidity, bias (THB) test at 85°C, 85% relative humidity, and an applied rated voltage for 1000 hours. In compliance with IEC 61071, the life expectancy is at least 100,000 hours. The capacitors bear the CE symbol, types with a can diameter of >40 mm are UL-approved, and the insulation of the connections conforms to UL 94 V0. In the event of excessive pressure in the capacitor case due to an overload, the integrated overpressure disconnection safety device isolates both terminals from the winding. Among other applications, the new capacitors can be used as output filters of photovoltaic inverters, frequency converters and uninterruptible power supplies.

TDK Corporation | www.epcos.com



Digital code linkage feature for solar water heating clients

The Solar Rating & Certification Corporation (ICC-SRCC), a program of the ICC Evaluation Service (ICC-ES), is expanding its solar water heating client offerings to include a new online code linkage feature. This feature will increase the visibility, awareness, and ease-of use of listings by linking the International Code Council's widely used, online code portals, publicACCESS, and premiumACCESS, to client listings. Specifiers, engineers, and code officials use these digital code websites on a regular basis to specify products or approve products for installation. Denoted by a green ICC-ES symbol, the links allow users to see a list of compliant solar thermal equipment and directly access the applicable listings on the ICC-SRCC website. Designed specifically for solar heating and cooling manufacturers by industry experts, the ICC-SRCC listing program saves manufacturers time and money, facilitates quick and accurate installations of solar thermal products, and provides high-quality listing information that code officials need to enforce the codes. ICC-SRCC listings show manufacturer compliance to all codes applicable to solar thermal equipment and components throughout the U.S.

ICC-SRCC | www.iccsafe.org



CONSTRUCTION



SOLAR ENERGY IS A BUSINESS WITHOUT BORDERS

PCL Construction's Solar Division is founded on our expertise delivering solar power in North America, the Caribbean, and Australia. Our brand is backed by a strong balance sheet and strength of resources distributed across 31 operational centers. Whatever you need – be it planning, design, engineering, construction or commissioning, PCL's solar experts are focused on your business priorities, guiding you seamlessly through all phases of EPC execution. Contact Andrew Moles at amoles@pcl.com or Patrick Malone at pmalone@pcl.com for more information.



Inverters

An integral part of any energy system, inverters convert the power generated from the sun into functional energy for grid and off-grid use. With technology offering ever-more efficient and reliable power generation, herein we highlight the latest in utility-scale, commercial, industrial, and residential inverters...

SEE AD ON PAGE 11



ABB

Product: TRIO-TM-60

Application: Commercial

Continuous Output Power: Up to 60kW

Weighted CEC Efficiency: 98%

Peak Efficiency Range: 98.5%

DC Voltage Operating Range: 360V to 950V

Operating Temperature Range: -13°F to 140°F (-25°C to 60°C) derating above 113°F (45°C)

Dimensions: 28.5" x 58.7" x 12.4" (724mm x 1491mm x 315mm)

Certifications/Approvals: UL 1741, UL 1741 SA, IEEE1547, Rule 21, HECO Rule 14h

Warranty: 10-year USA warranty, 5-year International warranty

Key Features:

- 3 MPPT and a wide input voltage range make this a powerful inverter;
- Configurable AC and DC compartments making design, installation, and servicing easy;
- Embedded secure wireless connection for easy commissioning and monitoring;
- Installations at any angle from 0° and 90°;
- Remote monitoring with Aurora Vision;
- Forced air cooling.

www.new.abb.com

SEE AD ON PAGE 13



Power Electronics

Product: HEM Central String Inverter FS3225MU

Application: Commercial, utility-scale, industrial

Continuous Output Power: 3225 @ 50°C, 3550 @ 25°C

Weighted CEC Efficiency: 98%

Peak Efficiency: 98.7%

DC Voltage Operating Range: 913Vdc to 1310Vdc

Operating Temperature Range: -31°F to 140°F (-35°C to 60°C)

Dimensions: 260" x 83.4" x 89" (6604mm x 2118mm x 2260mm)

Certifications/Approvals: UL1741SA, IEEE1547, EN62109-1, 62109-2SA, NEC2014/2017

Warranty: 5-year warranty

Key Features:

- Unique medium voltage inverter;
- Cyclone Cooling IP65 filterless air-cooled system;
- Field replaceable power modules;
- Integrated SCADA, aux. power, and recombinder;
- Nighttime transformer disconnect with ECON Mode.

www.power-electronics.com



Magnum Energy, a product brand of Sensata Technologies

Product: MicroGT 500 Microinverter

Application: Residential

Continuous Output Power: 500kW

Weighted CEC Efficiency: 95.5%

Peak Efficiency: 95.5%

DC Voltage Operating Range: 211V to 264V

Operating Temperature Range: -40°F to 149°F (-40°C to 65°C)

Dimensions: 8.75" x 6.5" x 1.1" (221mm x 167mm x 29mm)

Certifications/Approvals: Emissions & Immunity (EMC) Compliance FCC PART 15, ANSI C63.4 2003, ICES-003 Safety Class Compliance Grid Connection Compliance IEEE 1547 UL 1741, CSA C22.2, No. 107.1-01, NEC2014 690.12

Warranty: 25-year warranty

www.sensatapower.com



Sol-Ark.com (Portable Solar, LLC)

Product: Sol-Ark 8K

Application: Residential

Continuous Output Power: 8kW

Weighted CEC Efficiency: 96%

Peak Efficiency: 96.5%

DC Voltage Operating Range: 150V to 500V

Operating Temperature Range: 50°F to 113°F (-10°C to 45°C) can go higher but power will reduce

Dimensions: 25.6" x 18.8" x 7.1" (650mm x 477.5mm x 180mm)

Certifications/Approvals: Electronics certified by SGS labs, UL1741, IEEE1547, FCC 15 class B, UL1699B, MIL-STD461G, MIL-STD-188-125-1 (Independently tested May 2018)

Warranty: 5-year standard warranty, optional 10-year warranty available

www.sol-ark.com



Enphase Energy

Product: Enphase IQ 7X Microinverter

Application: Residential

Continuous Output Power: 315VA

Weighted CEC Efficiency: 97.5% @ 240V

Peak Efficiency: 320VA

DC Voltage Operating Range: 25V to 80V

Operating Temperature Range: -40°F to 140°F (-40°C to 60°C)

Dimensions: 8.34" x 6.88" x 1.18" (212mm x 175mm x 30.2mm)

Certifications/Approvals: CA Rule 21 (UL 1741-SA) UL 62109-1, UL1741/IEEE1547, FCC Part 15 Class B, ICES-0003 Class B, CAN/CSA-C22.2 NO. 107.1-01, UL Listed as PV Rapid Shut Down Equipment, conforms with NEC-2014 and NEC-2017 section 690.12 and C22.1-2015 Rule 64-218 Rapid Shutdown of PV Systems, for AC and DC conductors, when installed according manufacturer's instructions.

Warranty: 25-year warranty

www.enphase.com



Analytic Systems

Product: Intelligent Pure Sinewave Inverters

Application: Commercial, utility-scale, industrial, military, marine

Continuous Output Power: 360W to 3600W

Peak Efficiency: >90% @ maximum output

DC Voltage Operating Range: 10V to 140V

Operating Temperature Range: -13°F to 104°F (-25°C to 40°C), -40°F/ C optional

Dimensions: 15" x 12" x 8" (38.1cm x 30.4cm x 20.3cm)

Warranty: 3-year parts and labor warranty

www.analyticsystems.com



Chilicon Power

Product: CP-720

Application: Residential, commercial

Continuous Output Power: 720VA

Weighted CEC Efficiency: 96.5%

Peak Efficiency: 97%

DC Voltage Operating Range: 44V to 96V

Operating Temperature Range: -40°F to 149°F (-40°C to 65°C)

Dimensions: 12" x 8" x 1.8" (305mm x 203mm x 46mm)

Certifications/Approvals: Rule 21 / UL1741SA, IEEE std 1547, IEEE std C62.41.2, CSA C22.2 NO. 107.1 CISPR 22 Class B

Warranty: 25-year warranty

www.chiliconpower.com



SolarEdge

Product: EV-charging single-phase inverter

Application: Residential

Continuous Output Power: ≤32A @240V

Weighted CEC Efficiency: 99%

Peak Efficiency: 99.2%

DC Voltage Operating Range: Fixed voltage

Operating Temperature Range: -13°F to 140°F (-25°C to 60°C)

Dimensions: 17.7" x 14.6" x 6.8" (450mm x 370mm x 174mm) with safety switch

Certifications/Approvals: Intertek ETL listed, UL 2594:2016 ED.2, CSA C22.2#280:2016 ED.2, UL2594, UL2231-1, UL2231-2, NEC Article 625 compliant, SAE J1772-2009

Warranty: 12-year warranty, extendable to 20- or 25-years

www.solaredge.com/us

/ Perfect Welding / Solar Energy / Perfect Charging



ADAPTIVE SOLUTION FOR COMMERCIAL SOLAR THE FRONIUS ROOFTOP SOLUTION

/ **Fronius MC4 Connectors** - Reduce installation time, simplify system maintenance and improve technician safety with this optional adaption. Simply connect DC wires through MC4 connector cables and forgo of wiring inside the inverter.

/ **Fronius Symo SnapInverter** - The lightweight Fronius Symo 24kW allows for flexible mounting at any angle from vertical to completely flat. Fronius inverters require less hardware with an easy O&M design, thus major savings on cost!

/ **Fronius Symo Shade Cover** - Ensure maximum lifetime while keeping the inverter's temperature low and performance high. With rooftop inverter placement eliminate the need for Rapid Shutdown hardware, minimizing system design.

/ Learn more at www.fronius.com/usa. Contact us at (219)734-5500 or pv-sales-usa@fronius.com

SOLAR

SEE AD ON PAGE 34



Delta Electronics

Product: Delta 3 Phase Transformerless Solar Inverter M80U

Application: Commercial

Continuous Output Power: 83kW

Weighted CEC Efficiency: 98.5%

Peak Efficiency: 98.8%

DC Voltage Operating Range: 200V to 1000V

Operating Temperature Range: -13°F to 140°F (-25°C to 60°C)

Dimensions: 24.2" x 35.4" x 10.8" (614mm x 899mm x 274mm)

Certifications/Approvals: UL1741 SA, UL1741, UL1998, UL 1699B, IEEE1547, IEEE1547.1, CSA C22.2, FCC Part 15 (Class B)

Warranty: 10-year warranty

Key Features:

- Two-stage topology with wide input operation range;
- Allows 0-90° tilt-mount installation;
- Dual MPP tracker inputs and a wiring box capable of landing up to 18 strings via fused inputs;
- Integral DC Arc fault detector and integrated AC & DC disconnects;
- String monitoring and NEMA 4X outdoor rated enclosure.

www.delta-americas.com

SEE AD ON PAGE 06



CyboEnergy

Product: CyboInverter

Application: Commercial, residential, industrial

Continuous Output Power: 1.2kW

Peak Efficiency: 96%

DC Voltage Operating Range: 15V to 58V

Operating Temperature Range: -40°F to 149°F (-40°C to 65°C)

Dimensions: 12.5" x 9.5" x 2.3" (317.5mm x 241mm x 58.4mm)

Certifications/Approvals: UL1741, IEEE1547, CSA107.1, FCC, NEMA-6 (IP67)

Warranty: 3-year warranty with extended warranty options available

Key Features:

- On-Grid and On/Off-Grid CyboInverter for on-grid solar systems with backup power;
- Off-Grid CyboInverter H Model for electric water heaters;
- Battery-less Off-Grid CyboInverter Rx Model for Inverter-Air-Conditioners (IAC);
- Off-Grid CyboInverter for off-grid solar systems; mobile microgrids, EV charging;
- Dual-Output Off-Grid CyboInverter H/Nx Model for heating, cooling, and air-conditioning.

www.cyboenergy.com



Northern Electrical & Power

Product: Module Level Rapid Shutdown Device

Application: Commercial, residential, industrial

Continuous Output Power: 450W

DC Voltage Operating Range: <80Vdc per module. System voltage up to 1500Vdc.

Operating Temperature Range: -40°F to 185°F (-40°C to 85°C)

Dimensions: 6.69" x 4.72" x .98" (170mm x 120mm x 25mm)

Certifications/Approvals: NEC 2017 and NEC 2014, article 690.12 (certified)

Warranty: 10-year standard warranty, with extended options up to 25-years

www.northernep.com/en



Morningstar Corporation

Product: MultiWave Inverter/Charger (BOS version)

Application: Commercial, residential, industrial

Continuous Output Power: 4kW+

Weighted CEC Efficiency: TBD

Peak Efficiency: 95%

DC Voltage Operating Range: 36V to 64V

Operating Temperature Range: -40°F to 140°F (-40°C to 60°C)

Dimensions: 31.14" x 18.43" x 9.37" (79.09cm x 46.81cm x 23.8cm)

Certifications/Approvals: UL 1741, IEC 62109-2

Warranty: 5-year warranty

www.morningstarcorp.com

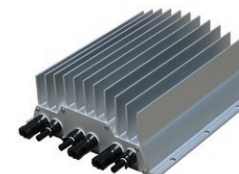

Ampt, LLC

Product: DC String Optimizer

Application: Commercial, utility-scale, industrial, microgrid

Continuous Output Power: 4.9kWdc to 28kWdc

Weighted CEC Efficiency: Up to 99.5%

Peak Efficiency: Up to 99.6%

DC Voltage Operating Range: Up to 1500V

Operating Temperature Range: -40°F to 167°F (-40°C to 75°C)

Dimensions: 10.7" x 8.66" x 3.93" (272mm x 220mm x 100mm)

Certifications/Approvals: ETL to UL 1741, IEC 61000-6-1, 61000-6-3, 62109; CE, Giteki 2-1-19; FCC Part 15, class A.

Warranty: Standard and extended warranties available

www.ampt.com

SEE AD ON PAGE 03



Growatt New Energy Technology Co., Ltd.

Product: Growatt 33000/36000/40000 TL3-US

Application: Commercial, utility-scale, residential, industrial

Continuous Output Power: 33kW to 40kW

Weighted CEC Efficiency: 98.5%

Peak Efficiency: 98.8%

DC Voltage Operating Range: 200V to 1000V

Operating Temperature Range: -13°F to 140°F (-25°C to 60°C)

Dimensions: 17.32" x 31.1" x 10.83" (440mm x 790mm x 275mm)

Certifications/Approvals: UL1741SA, UL1998, UL 508C, IEEE1547, FCC part 15(class B), CSA C22.2 No.107.1, CSA C22.2 NO.14

Warranty: 5-,10-,15-year warranty

Key Features:

- Maximum efficiency up to 99%;
- 2 MPPTs;
- String monitoring;
- Advanced Intelligent Power Module (IPM);
- Compact design.

www.growatt-america.com

SEE AD ON PAGE 36



TMEiC

Product: Solar Ware Samurai Series

Application: Utility-scale

Continuous Output Power: 3360kW

Weighted CEC Efficiency: 99%

Peak Efficiency: 99.1%

DC Voltage Operating Range: 800V to 1300V

Operating Temperature Range: -4°F to 122°F (-20°C to 50°C); -4°F to 104°F (-20° to 40°C) without derating, >104°F (>40°C) derating

Dimensions: 92" x 197" x 46" (2286mm x 5000mm x 1150mm)

Certifications/Approvals: UL1741/CSA C22.1 107.1/IEEE1547; UL1741 Supplement SA; NEC standard

Warranty: 5-year standard warranty, extended warranty up to 20-years

Key Features:

- 2500kW to 3360kW, 1500 Vdc, UL Certified 1741 SA;
- High-yield power generation;
- Maximum efficiency of 99%;
- Wide MPPT range;
- NEMA 3R/4R outdoor enclosure;
- Build large projects with fewer inverters, reduce site work and BOS cost.

www.tmeic.com



APsystems

Product: APsystems YC600 microinverter

Application: Commercial, residential, industrial

Continuous Output Power: 548VA

Weighted CEC Efficiency: 96.5%

Peak Efficiency: 96.7%

DC Voltage Operating Range: 16V to 55V

Operating Temperature Range: -40°F to 149°F (-40°C to 65°C)

Dimensions: 10.24" x 7.4" x 1.24" (260mm x 188mm x 31.5mm)

Certifications/Approvals: UL 1741, UL 1741 SA, IEEE-1547, CSA C22.2 No. 107.1-01, NEC 2017 690.12 FCC PART 15, ANSI C63.4, ICES-003

Warranty: 10-year and 25-year warranty options

usa.apsystems.com

COTEK SD Series Pure Sine Wave Inverters



SD 3500

KEY FEATURES:

- Available in 2500W and 3500W
- Built-in AC transfer switch
- Parallel and N+1 design for power expansion
- Hardwire and GFCI/Schuko versions
- Wide DC input range & operating temperature
- Light weight & low profile
- Intelligent software for power management
- Advanced protection features
- Adjustable power saving options

COTEK is a global leader in the manufacture of off-grid, battery-based pure sine wave inverters. This product-line enhances the reputation that COTEK has established since 1986 for innovative technology and total quality assurance. With a 2 year warranty and excellent customer support, the SD series will soon become the industry standard.



CR-10 Remote



COTEK The Americas - now serving Latin America!
For complete product specifications visit: www.cotek.ca

SOLAR

SEE AD ON PAGE 31



Fronius USA

Product: Fronius Primo SnapInverter

Application: Commercial, residential

Continuous Output Power: 3.8kW to 15kW

Weighted CEC Efficiency: 96.5%

Peak Efficiency: 97%

Dimensions: 20.1" x 28.5" x 8.9" (510mm x 724mm x 226mm)

Certifications/Approvals: UL 1741-2010 Second Edition (incl. UL1741 Supplement SA 2016-09 for California Rule 21 and Hawaiian Electric Code Rule 14H), UL1998 (for functions: AFCI, RCMU and isolation monitoring), IEEE 1547-2003, IEEE 1547.1-2003, ANSI/IEEE C62.41, FCC Part 15 A & B, NEC 2017 Article 690, C22.2 No. 107.1-16, UL1699B Issue 2 -2013, CSA TIL M-07 Issue 1 -2013

Warranty: 10-year warranty

Key Features:

- Transformerless single phase inverter 3.8 - 15 kW;
- Easy to install hinged mounting system;
- Board level serviceability, avoid inverter replacements and keep installations sustainable;
- Dual powerpoint trackers, high system voltage, a wide input voltage range, Wi-Fi* and SunSpec Modbus interface, and Fronius online and mobile monitoring platform Fronius Solar.

www.fronius-usa.com

SEE AD ON PAGE 33



COTEK Electronic Industrial Co. Ltd.

Product: SD3500-xxx

Application: Commercial/industrial

Continuous Output Power: 3.5kW

Weighted CEC Efficiency: 90%

Peak Efficiency: 91%

DC Voltage Operating Range: 20V to 32V for 24V model

Operating Temperature Range: -4°F to 140°F (-20°C to 60°C)

Dimensions: 11.14" x 5.04" x 19.53" (283mm x 128mm x 496mm)

Certifications/Approvals: UL458 / EN60950-1

Warranty: 2-year warranty

Key Features:

- Parallel N+1 redundancy design for power expansion;
- Built-in ATS & AC circuit breaker;
- RS232 communication;
- Fully isolated input & output;
- Multiple industrial for single and 3-phase applications.

www.cotek.com

The Perfect All-in-One PV/Energy Storage Inverter

M & E Series Inverter

Smart Energy Home Solutions

For more information, contact us at:
inverter.sales@deltaww.com
www.delta-americas.com/solarinverters



Yaskawa Solectria Solar

Product: SOLECTRIA XGI 1000

Application: Commercial

Continuous Output Power: 50kW, 60kW, 65kW

Weighted CEC Efficiency: 98%

Peak Efficiency: 98.2%

DC Voltage Operating Range: 350V to 950V

Operating Temperature Range: -40°F to 140°F (-40°C to 60°C)

Dimensions: 45.8" x 28.3" x 11.6" (1163mm x 718.8mm x 294.6mm)

Certifications/Approvals: UL 1741 / IEEE 1547, UL 1699B, UL 1998

Warranty: 10-year standard warranty with 15- and 20-year options

www.solectria.com



Ingeteam

Product: Ingecon SUN 1800TL U B690

Application: Utility-scale, commercial

Continuous Output Power: 1793kVA

Weighted CEC Efficiency: 98.5%

Peak Efficiency: 98.9%

DC Voltage Operating Range: 996V to 1500V

Operating Temperature Range: -4°F to 140°F (-20°C to 60°C)

Dimensions: 222" x 36.2" x 86.6" (563.88cm x 91.94cm x 219.96cm)

Certifications/Approvals: UL1741-SA

Warranty: 5-year standard warranty, with extended warranty options up to 25 years

www.ingetteam.com

SEE AD ON PAGE 36



TMEIC

Product: 2.5MW Energy Storage Inverter

Application: Utility-scale

Continuous Output Power: 2.5MVA

Weighted CEC Efficiency: pending, under development

Peak Efficiency: 98% target

DC Voltage Operating Range: 750V to 1250V

Operating Temperature Range: -4°F to 122°F (-20°C to 50°C); -4°F to 104°F (-20° to 40°C) without derating, >104°F (>40°C) derating

Dimensions: 90" x 200" x 76" (2286mm x 5080mm x 1930mm)

Certifications/Approvals: pending, under development

Warranty: pending, under development

Key Features:

- Available October, 2018;
- Four-quadrant operation support (P, Q operation);
- Grid support - Low and high voltage ride-through (LVRT & HVRT). Frequency ride-through (FRT) and Islanding detection;
- Communication via Ethernet and MODBUS between PCS and PLC.

www.tmeic.com

SEE AD ON PAGE 37



Sinexcel, Inc.

Product: Modular bi-directional storage inverter

Application: Commercial, utility-scale, industrial

Continuous Output Power: 62.5kW to 500kW

Peak Efficiency: 98.2%

DC Voltage Operating Range: 600V to 900V

Operating Temperature Range: -4°F to 122°F (-20°C to 50°C)

Dimensions: 43" x 31.5" x 85" (1100mm x 800mm x 2160mm)

Certifications/Approvals: ETL certified conforming to UL1741/CSA22.2/IEEE1547/CPUC RULE 21 / CE EMC: IEC61000, CE LVD: IEC62477, /G59/ AS4777 (Pending)

Key Features:

- The modular and ETL certified bi-directional inverter, with optional multi-strings-battery tech and same size of PCS cabinet;
- Can work in two modes: utility-interactive mode (P-Q mode), and stand-alone mode (off-grid mode, or V-F mode);
- The external isolation transformer can offer 480Vac or 400Vac 3P4W connection to the distribution system or load for grid-forming operation.

www.sinexcel.us



Tabuchi Electric Company of America

Product: EIBS16GU2, EIBS16GU2 PLUS

Application: Residential

Continuous Output Power: 5.5kW

Weighted CEC Efficiency: 94.5%

Peak Efficiency: 95.6%

DC Voltage Operating Range: 80V to 550V

Operating Temperature Range: -4°F to 104°F (-20°C to 40°C)

Dimensions: 9.8" x 26.8" x 47.2" (249mm x 681mm x 1199mm)

Certifications/Approvals: (Inverter) UL1741/UL1741 SA/UL 1699B/UL60950-1, CSA C22.2 No. 107.1/No. 60950-1, IEEE 1547a, CES-listed, FCC class B; (Battery) UL 1973, CSA C22.2 No. 60950-1, (System) ANSI/CAN/UL9540

Warranty: 10-year warranty

www.tabuchiamerica.com



Ideal Power, Inc.

Product: Stabiliti Series 30kW Multiport Power Conversion System

Application: Commercial

Continuous Output Power: 30kW

Weighted CEC Efficiency: 95% est.

Peak Efficiency: 95.5%

DC Voltage Operating Range: 100V to 1000V

Operating Temperature Range: -13°F to 122°F (-25°C to 50°C), derated >122°F (50°C)

Dimensions: 20.5" x 40" x 16" (520mm x 1016mm x 406mm)

Certifications/Approvals: UL1741, UL1741SA, IEEE1547a, CA Rule 21, PJM, RoHS and REACH Compliant

Warranty: 10-year limited North America warranty, 5-year limited international warranty

www.idealpower.com



Go Electric, Inc.

Product: LYNC DR Energy Storage Inverter & Microgrid Controller

Application: Commercial, utility-scale, industrial

Continuous Output Power: 250kW

Weighted CEC Efficiency: 95%

Peak Efficiency: 99%

DC Voltage Operating Range: 580V to 800V

Operating Temperature Range: 32°F to 122°F (0°C to 50°C)

Dimensions: 96" x 64" x 71.5" (244cm x 162cm x 181cm)

Certifications/Approvals: UL1741.1, IEEE 1547.1, CSA C22.2

Warranty: 10-year warranty

www.goelectricinc.com



Alencon Systems, LLC

Product: Alencon SPOT

Application: Commercial, utility-scale, industrial

Continuous Output Power: 25kW to 45kW

Weighted CEC Efficiency: 98% to 99%

Peak Efficiency: 98.6%

DC Voltage Operating Range: 600V to 1500V

Operating Temperature Range: -22°F to 122°F (-30°C to 50°C)

Certifications/Approvals: UL1741, CSA 22.2, IEC62109-1

Warranty: 5-year standard warranty, up to 20-year extended warranties optional

www.alenconsystems.com

ENERGY STORAGE

SEE AD ON PAGE 71



Rhombus Energy Solutions

Product: Rhombus 30/60 Site Inverter System

Application: Commercial, industrial

Continuous Output Power: 30kW continuous output per stage (two stage option)

Weighted CEC Efficiency: 94%

Peak Efficiency: 97%

DC Voltage Operating Range: 270V to 875V

Operating Temperature Range: -4°F to 122°F (-20°C to 40°C)

Dimensions: 31" x 23" x 70" (787m x 584mm x 1178mm)

Certifications/Approvals: UL1741 SA, UL2202, UL2231 Certified, NEMA 3R and SunSpec compliant

Warranty: 2-year standard warranty with extended option available

Key Features:

- Maximum flexibility with two, 30kW independent, power stages that can be configured in multiple ways;
- Integrated VectorStat site controller that can be configured as a mesh or "hub and spoke" SCADA configuration;
- Multi-mode, multi-port, utility interactive bi-directional inverter for on and off-grid connections;
- Power converter for distributed energy resources in grid or island mode;
- Integrated isolation transformer.

www.rhombusenergy.com

SEE AD ON PAGE 34



Delta Electronics

Product: Power Conditioning Solutions (PCS125)

Application: Commercial, industrial, utility scale

Continuous Output Power: 125kVA

Weighted CEC Efficiency: 97.5%

Peak Efficiency: 97.8%

DC Voltage Operating Range: 750V to 1000V

Operating Temperature Range: -13°F to 140°F (-25°C to 60°C) derating >50°C (3%/°C), ≤2000m; -13°F to 104°F (-25°C to 40°C), >2000m

Dimensions: 23.6" x 31.5" x 69.5" (600mm x 800mm x 1766mm)

Certifications/Approvals: UL1741, UL 1741 SA, IEEEE1547, Rule 21, FCC part 15 class A, HECO Listed, CEC Listed

Warranty: 10-year warranty

Key Features:

- Highly efficient AC coupled bi-directional power conversion; power scalable in 125kW increments to 500kW;
- Flexible integrated PCS125 and Energy Storage Solution (ESS) skid solutions minimize installation and commissioning costs;
- ESS system: scalable in increments of 84kWh to 1MWh+; -13°F to 122°F (-25°C to 50°C); 31.5" x 44.3" x 93.7" (800mm x 1126mm x 2380mm); UL 1973, IEC 61000-6-2 / 61000-6-3, FCC Part15 Class B, UL 50E;
- Partnered with major battery suppliers enabling up to 4 hours of backup;
- Applications for peak shaving, load shifting, power backup, and PV smoothing.

www.delta-americas.com

SEE AD ON PAGE 19



Dynapower Company, LLC

Product: DPS-250 DC-DC Converter

Application: Utility-scale

Continuous Output Power: 250kW

Peak Efficiency: 98.2%

DC Voltage Operating Range: 550V to 1500V

Operating Temperature Range: 14°F to 122°F (-10°C to 50°C)

Dimensions: 33.5" x 39.4" x 80.5" (851mm x 1001mm x 2045mm)

Certifications/Approvals: UI 1741

Warranty: 5-year warranty

Key Features:

- Parallel up to 8 units (2MW);
- For use with existing or new 1,000V to 1,500V PV arrays and central inverters;
- Capable of clipping recapture and low-voltage harvest;
- Integrated DC Disconnect and DC Input Fuses;
- Available with fully integrated BESS.

www.dynapower.com



Solar Ware® Samurai Series, a level above the competition.

Our installed North American base of 3 GW, composed of more than 1,800 PV inverters, has provided exceptional reliability, with fleet availability of 99.87%.

TMEiC offers Utility-Scale Photovoltaic Inverters, Energy Storage, Site Control.

www.tmeic.com | 1-540-283-2000 | E: SolarPV@tmeic.com | Roanoke, Virginia USA

SEE AD ON PAGE 13



Power Electronics

Product: HEMK Central String Inverter FS3450KU

Application: Commercial, utility-scale, industrial

Continuous Output Power: 3450 @ 50°C, 3800 @ 25°C

Weighted CEC Efficiency: 98.5%

Peak Efficiency: 98.7%

DC Voltage Operating Range: 976V to 1310V

Operating Temperature Range: -31°F to 140°F (-35°C to 60°C)

Dimensions: 144" x 83.4" x 89" (3657mm x 2118mm x 2260mm)

Certifications/Approvals: UL1741SA, IEEE1547, EN62109-1, 62109-2SA, NEC2014/2017

Warranty: 3-year warranty

Key Features:

- Compatible pairing to all battery types with adjustable AC voltage;
- Cyclone cooling IP65 filterless air-cooled system;
- Field replaceable power modules;
- Easy integration with SCADA system;
- Integrated SCADA, aux. power and recombinder.

www.power-electronics.com

SEE AD ON PAGE 03



Growatt New Energy Technology Co., Ltd.

Product: Hybrid inverter SPH series

Application: Commercial, utility-scale, residential, industrial

Continuous Output Power: 3kW to 6kW

Weighted CEC Efficiency: 97.5%

Peak Efficiency: 97.5%

DC Voltage Operating Range: 120V to 550V

Operating Temperature Range: -13°F to 140°F (-25°C to 60°C)

Dimensions: 21.5" x 20.3" x 6.7" (547mm x 516mm x 170mm)

Certifications/Approvals: UL1741, CE, IEC62109, G83/G59, VDE0126-1-1, AS4777, AS/NZS 3100, CEI 0-21, VDE-AR-N4105, VFR 2014, En50438, IEC 61727, IEC 62116

Warranty: 5-,10-year warranty

Key Features:

- Dual MPPTs;
- Flexible configuration;
- Natural cooling;
- Multiple working models to maximize system self-consumption, and save on electricity bills.

www.growatt-america.com



AIMS Power

Product: DC to AC Pure Sine Inverter with Automatic Transfer Switch 2000 Watt

Application: Commercial, residential, industrial

Continuous Output Power: 2kW

Weighted CEC Efficiency: 88%

Peak Efficiency Range: 92%

DC Voltage Operating Range: 12V

Operating Temperature Range: 14°F to 104°F (-10°C to 40°C)

Dimensions: 21.5" x 9.5" x 3.5" (546mm x 241mm x 89mm)

Certifications/Approvals: UL 458

Warranty: 2-year warranty

www.aimscorp.net

Darfon America

Product: H5001 Hybrid Inverter

Application: Commercial, residential

Continuous Output Power: 5kW

Weighted CEC Efficiency: 95.5%

Peak Efficiency: 96%

DC Voltage Operating Range: 120V to 500V

Operating Temperature Range: 32°F to 131°F (0°C to 55°C)

Dimensions: 39" x 17.6" x 5.9" (990mm x 448mm x 150mm)

Certifications/Approvals: UL1741SA, CSA, IEEE 1547, FCC Class B

Warranty: 5-year warranty

www.darfonsolar.com

Energport Battery Energy Storage System

EES North American Booth : 8420

Driven By **Sinexcel**

AC RACK L3060



- 30kW Sinexcel PCS
- 64.5kWh Battery
- LFP Li-ion Battery
- Small footprint
- Easy install
- EMS included
- Remote monitor
- 480V 3p
- ETL Certified
- CA SGIP Approved

- Demand Charge Bill Savings
- PV Self-Consumption
- Backup Power for Emergency
- Turnkey Solutions
- In Stock Now in Bay Area
- Dealer / Installer Wanted
- 10 Year Warranty

Storage Inverters 30~500kW

- cETLus listed according to UL9540/UL1741SA/CSA22.2
- HECO CGS/CSS listed
- CPUC listed
- Grid-interactive & Grid-forming

Outdoor Commercial & Industrial Battery Energy Storage Solutions



30kW

50-150kW

250-500kW

Sinexcel Inc. <http://www.sinexcel.us/henry@sinexcel.us>

Energport Inc. <http://www.energport.com/info@energport.com>

INTERSOLAR NORTH AMERICA 2018

July 10th-12th, 2018

Moscone Center — San Francisco, CA

Intersolar's exhibition and conference both focus on the areas of photovoltaics, PV production technologies, smart renewable energy, and solar thermal technologies. Since being founded, Intersolar has become an important industry platform for manufacturers, suppliers, distributors, service providers, and partners of the solar industry.

www.intersolar.us

show in print

Features just some of the companies and technologies attendees will see at this year's show.

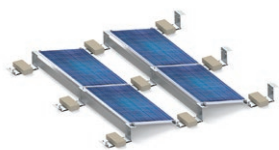

Simple non-penetrating solar mounting solution

EkonoRack 2.0 is a simple, non-penetrating solar mounting solution for commercial flat rooftops. The system's ETL Certification attests to its high standard of safety and robust design, allowing it to be grounded with only one grounding lug per array. EkonoRack 2.0's innovative design is composed of only one major component, acting as a ballast tray windshield mount and multiple panel support. The system's pre-attached roof mats save time on installation and provide maximum protection for the roof. KB RACKING offers a 10-year standard product warranty.

KB Racking | www.kbracking.com
Booth 9121



Inverter with heat-pipe based hybrid cooling

The Solar Ware Samurai Series utility-scale central inverters offer high efficiency (up to 99%) and reliability. This UL Certified 1741 SA inverter utilizes TMEIC heat pipe technology, it runs without fan operation up to 50% load. Heat-pipe cooling significantly simplifies thermal management; it uses fewer parts and a slow-speed fan with a heat-pipe heat sink. Manufactured in Houston, Texas, the series offers a wide MPPT range and power classes from 2500kW to 3360 kW at 1500Vdc. It includes a NEMA 3R/4R outdoor enclosure and allows users to build large projects with fewer inverters, reduce site work, and BOS cost.

TMEIC | www.tmeic.com
Booth 8511



Solar cable management

CAB Solar Cable Management is a unique solution to cable management in large-scale projects. The system uses patented designs to carry all types of cables and includes multi-carrier hangers for DC feeders, string wiring, data/comm, and power. The new, patent-pending, CAB Integrated Grounding System uses a copper composite messenger wire to both provide cable management and act as the EGC and GEC for the system. The Cambria County Association for the Blind and Handicapped, located in Western PA, is the manufacturer of all CAB Products. These products provide employment and rehabilitation opportunities for persons with physical and intellectual disabilities.

CAB Solar | www.cabproducts.com
Booth 9115



Simplified solar mounting system

Preformed Line Products introduces the POWER MAX Ballasted Roof Mounting System. The POWER MAX solar mounting system is engineered to maximize energy output on commercial flat roofs. Developed with the professional installer in mind, this system features 50% fewer components and a simplified design resulting in faster assembly rates and labor savings on every project. Available in a flush mount, 5° or 10° tilt, or higher density dual tilt design, the POWER MAX base arrives stacked on pallets providing easy transport to the roof. Engineered as a fully ballasted, non-penetrating system, it accepts standard concrete blocks and is qualified by wind tunnel testing.

Preformed Line Products
www.preformed.com
Booth 9418

www.axitecsolar.us

AXITEC[®]
high quality german solar brand

High Performance Solar Modules

15
YEARS
Warranty

25
YEARS
85%

- AXIpower POLY up to 330 Watt
- AXIpremium MONO up to 360 Watt
- AXIblackpremium MONO ALL BLACK up to 290 Watt

AXITEC, LLC, 1819 Underwood BLVD, Suite 5, Delran, New Jersey 08075,
Phone 856-393-7800, info@axitecsolar.com



Advancing solar throughout the world

EnergyBin.com is a B2B, member-only community and online marketplace for the solar industry providing trusted, centralized access to competitively priced components. EnergyBin facilitates the brokering, movement, and commerce of new, excess, used, refurbished, and legacy solar components and provides critical supply-chain intelligence. As a U.S. Department of Energy SunShot Initiative awardee, EnergyBin has lowered residential and commercial project capital costs by 20+% on equipment.

EnergyBin | www.energybin.com
Booth 7238



Long lasting, safe, and reliable energy storage solutions

K2 Energy Solutions LiFePO4 Batteries are available in both power-optimized and energy-optimized versions. These batteries are customizable through cell chemistry, monitoring and control electronics, as well as cell balancing. Each battery can perform as a single unit or be connected in parallel or series to create larger systems to fit the application. In many cases K2 Batteries can be "drop-in" lead-acid replacements. These batteries are a solution for UPS systems or solar applications.

K2 Energy | www.k2battery.com
Booth 8033



Turnkey solar tracker

Solar FlexRack's latest tracker technology bundles an advanced tracker design with full project support services reducing solar project costs and risks. Engineered for high performance, BalanceTrac technology supports high energy yield designs and reduces wear and tear on components for longer lasting tracker equipment. Features include:

- Up to 90 modules per row;
- Rotational range of 110° (± 55°);
- Optimized for 1000 and 1500V modules;
- Low per-unit fixed costs for BOS savings;
- and New wind damper technology to mitigate wind conditions.

Solar FlexRack
www.solarflexrack.com
Booth 9619

From both sides now.



Single-Axis
Tracker



[PV SOLAR TRACKER]
E476688



**SCAN THIS QR CODE
AND DISCOVER ALL
THE SF7 FEATURES**



Soltec

SF7 Single-Axis Tracker standard features provide for drop-in bifacial compatibility with higher mounting height, shadow-free backside, and wide-aisle reflecting surfaces. In addition to intrinsically optimizing bifacial gain, the standard features enable other economic and performance benefits compared to the leading competitors.



Efficient solar inverter and energy storage solutions

Delta Electronics residential energy storage turnkey system, Delta E series, supports DC-coupled and AC-coupled battery systems for pure, or PV-combined storage systems. The Delta E series has built-in EMS and supports self-consumption, zero export, TOU, and off-grid modes with available back-up mode and dark start operation. With smart cloud technology, E series inverters support remote firmware upgrade, parameter modification, and one button RMA service and can also support Wi-Fi/Ethernet, cellular communication, and Bluetooth.

Delta Electronics (Americas) Ltd.
www.delta-americas.com
Booth 8421



Solar structure design and construction

M Bar C Construction Inc. provides reliable solutions for EPC's, electrical contractors, general contractors, corporate divisions, and government entities working on small or large scale projects. Using heavy and light gauge structural steel, they can incorporate solar efficiency into parking lot canopies, fixed and tracker ground-mount, and parking structure canopies. M Bar C installed 81MW of solar canopies in 2017. Their solutions are designed to be cost efficient for the long term needs of the customer. M Bar C is licensed and compliant with Cal/OSHA safety programs and prevailing wage jobs. CSLB# 869960.

M Bar C Construction, Inc.
www.mbarconline.com
Booth 9217



Advanced residential and commercial solar solutions

California-based Solaria Corporation's rooftop product, the PowerXT is a high value, aesthetic, and high energy yield solar module. Suited for space-constrained roofs, Solaria's sleek high output modules feature a black backsheet and attractive appearance. The proprietary PowerXT plat uniform form uses Solaria's advanced cell interconnect and module production processes, significantly boosting power generation and performance. High energy yield PowerXT modules ensure solar installers maximize power deployment on customer roofs - enabling them to install attractive, cost-effective on-site power plants that accelerate payback period and profitability.

Solaria Corporation | www.solaria.com
Booth 7130



Commercial & industrial battery energy storage solutions

Sinexcel Inc., located in CA, US, provides various semi-integrated energy storage systems including storage inverters, outdoor cabinets/containers, distribution systems, and optional HVAC and fire extinguishing systems, but without EMS and Battery. The products are used for residential community, commercial, and industrial applications. The products are based on the ETL/CPUC/HECOgy listed PCS with a power range from 30kW to 500kW per unit. They have both grid-forming and grid-following features, and could be used for either storage-only or solar+storage hybrid applications. With a standard MODBUS MESA compatible protocol, different kinds of batteries could be easily integrated and be used as a plug-&-play BESS.

Sinexcel | www.sinexcel.us
Booth 8420



Avoid main panel upgrades

QF Energy helps customers avoid main service panel upgrades with the B3 Bypass. The NEC 120% rule limits the amount of power production sources (PV, batteries, generators) that can be connected to a main panel. The B3 Bypass is a UL certified over current device that doesn't connect to the load center busbar, so the NEC 120% rule doesn't apply. The B3 Bypass allows the interconnection of PV, ESS, and EV chargers without the need to upgrade main service panels (load centers).

QF Energy | www.qfe002.com
Booth 8610



Try Our New Online Configurator



FastRack510™

- Commercial Flat Roof and Ground Mount PV
- Integrated 5° and 10° tilt options
- Inner-row spacing at 10" or 13"
- Quick installation with all top mount hardware
- Compatible with all framed modules
- Fully ballasted with optional mechanical anchors
- Roof friendly with low PSF
- Full engineering services available
- UL1703 Class A - UL 467



Visit us at InterSolar
Booth #9215

415-515-8710
www.sollega.com
info@sollega.com



Utility-scale solar products and services

PVH is a supplier of structures for PV facilities, and a manufacturer of single-axis solar trackers and SCADA control systems for utility-scale plants. Its Monoline and Axone trackers are designed to be simple to assemble, with 25-year design life, low-maintenance, and compatible with most SCADA systems by remote control. In addition, and to get the most out of photovoltaic projects, PVH also offers cleaning solutions with its PV Cleaner, a tool for areas where constant cleanups are required throughout the year, allowing a 30% improvement in the productivity of PV plants of any size.

PV Hardware (PVH)
www.pvhardware.com
Booth 9210



Integrating storage into solar installations

SimpliPhi's plug-and-play, all-in-one AccES residential energy storage system streamlines equipment and costs by integrating power storage into new/existing on/off grid solar installations. AccES combines SimpliPhi's cobalt-free, non-toxic LFP batteries with inverter charge controllers, power electronics, and system management in a NEMA 3R outdoor-rated box. Available with 14kWh of storage, AccES can scale up for additional power output and capacity and be safely installed indoors or outside in temperatures from -4°F to 122°F with no risk of thermal runaway or fire. AccES can be charged with solar, grid, or generator power and comes pre-wired and programmed.

SimpliPhi Power
www.simpliphipower.com
Booth 8217



Small components. Big Impact!

Stäubli Electrical Connectors' (formerly Multi-Contact) MC4 photovoltaic connectors are the global industry standard and can be found on more PV modules than any other connector system in the world. With more than 1.5 billion installed PV connector components, Stäubli Electrical Connectors provides more than 200 GW or 50% of the worldwide PV capacity.

The MC4 connector system is rated up to 1500 V UL, 1500 V TÜV safety class 0 and is available for 14 through 8 AWG cable configurations. We are also offering the in-line fuse PV-K/ILF connector for very low energy loss and heat generation featuring a robust IP68 enclosure.

**inter
solar**

connecting solar business | NORTH AMERICA | July 10-12, 2018. San Francisco, CA **Booth #8711**

Contact us today!

ec.us@staubli.com | +1 (707) 838-0530

www.staubli-alternative-energies.com

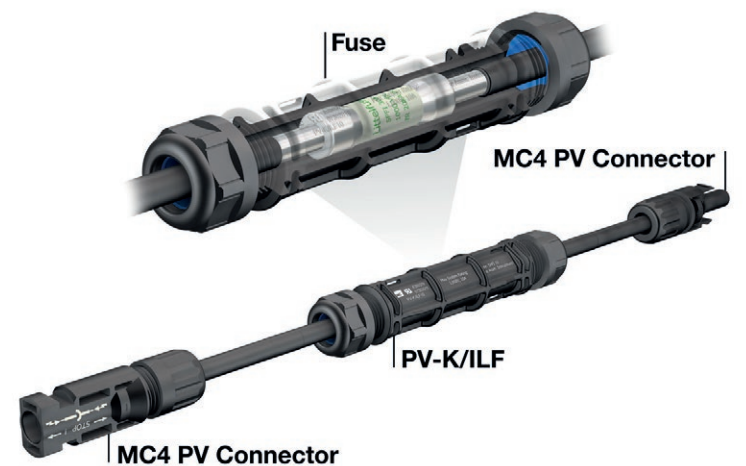

Multi-Contact

MC

STÄUBLI



Heavy-duty flooded and maintenance-free AGM batteries

With a full range of capacity options (80-4860 AH) and voltage configurations, Rolls heavy duty flooded and maintenance-free AGM models offer durable construction and reliable energy storage solutions for use in off-grid, grid-tied, or backup applications. With high cycle life and 10-year warranty on the industrial-grade Series 5000 range, Rolls batteries continue to deliver value and peace of mind for renewable energy customers.

Rolls Battery Engineering | www.rollsbattery.com
Booth 8029



Hybrid lead-acid battery

MK Battery's Deka Solar line includes sealed lead acid GEL and AGM batteries and select flooded products. The new UltraBattery is a hybrid device – a chemical combination of a lead-acid battery and an ultracapacitor, achieving higher-rate, partial-state-of-charge operation with extended longevity and high efficiency. Its unique chemistry not only increases power handling but vastly reduces hard sulfation, facilitating excellent longevity, and allowing it run for long durations between refresh charges. The UltraBattery is a solution for low voltage home and commercial use, as well as high-voltage grid applications. It's extremely efficient; up to 90-95% of every unit of energy stored is available for re-use when used in partial-state-of-charge. Like all batteries in the lead-acid family, UltraBattery is fully sustainable with its closed loop recycling.

MK Battery - Deka Solar
www.mkbattery.com
Booth 8228

PV KIT™ 2.0 IMPROVED DESIGN. EASIER TO INSTALL.

S-5!® has introduced a new and improved PV Kit, boasting lower installation time and cost for PV flush-mounting. The kit comes preassembled with both MidGrab and EdgeGrab for easier and more efficient installation. A single tool drives the top bolt, eliminating several installation steps. The PV Kit 2.0 features more aggressive bonding teeth for better grounding. Fewer lugs/ground wires required.

PV KIT 2.0 ADVANTAGES

- Pre-assembled components save time and money
- Only one tool needed for installation
- Bolt head uses standard hex bit tip which is provided
- Improved single piece EdgeGrab installs with ease
- Low profile bolt head provides a flush, clean finish
- Also available in black by special order
- One inch gap between modules, allowing load reduction per ASCE7
- UL 2703 Listed (Pending)

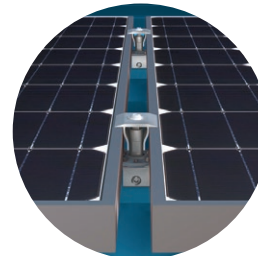

Top: PV Kit™ 2.0 with EdgeGrab
 Bottom: PV Kit™ with MidGrab



The Right Way!™ | www.s-5.com | 888-825-3432

SOLAR CONNECTIONS INTERNATIONAL

THE FUTURE OF SOLAR ATTACHMENTS

R-PANEL POWERMOUNT W/ SOLAR CONNECTION KIT

Rail-Less System Shown

**CABLE MANAGEMENT DISC
 SIMPLIFIES INSTALLATION AND
 ENSURES A CLEAN SET UP**

UL 1703 AND 2703 LISTED AND APPROVED

UNIVERSAL MID/END CLAMP



NEW!
**Single-Piece
 PowerMount
 Design**

Solar mounting sheathing attachment

Zilla's patented Double Stud XL Flashing Assembly attaches directly to sheathing while also providing the option for structural members if necessary. Without having to locate structure, the Zilla Double Stud XL eliminates the need for installation prep work, standardizes design and installation processes, achieves greater speed and flexibility in the field, and makes it possible to complete more projects in less time at less cost. Zilla Double Stud XL is compatible with Zilla flush mount systems or any solar mounting system to help drive better bottom line results.

Zilla Corporation | www.zillarac.com
Booth 9515

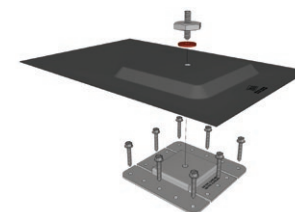



Watertight solar racking connection

PowerGrip Universal (PGU) is an attachment anchor for mounting solar racking systems and other products to any type of commercial roof. It's designed to reduce or eliminate ballast in commercial solar racking systems, so there's less weight on the roof. PGUs are made of heavy-duty cast aluminum, and include a base ring and a protective cover plate to keep water from infiltrating the roof assembly. PowerGrip Universal units transfer the load to the structural roof deck and do not require membrane welding. Typical installation time is less than five minutes and each unit provides up to 3300lbs of tensile strength, 2500lbs of shear strength, and can support compressive loads up to 2000lbs.

OMG Roofing Products | www.omgroofing.com

Booth 9435

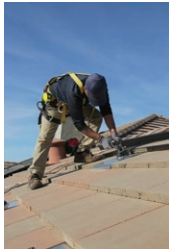

Racking & mounting solutions for all roof types

Quick Mount PV's QRail Series is a fully integrated mounting and racking system for fast, cost effective rooftop solar installation. The QRail features a simple and elegant racking system, and comes standard with the QDesign software application for optimal solar array design. Patented QClick technology enables module clamps to snap into place and remain upright, ready to accept modules. The QSplice internal bonded structural splice makes extending rails fast and easy, with no tools or extra parts required. Fully integrated electrical bonding and multiple rail sizes meet all load requirements. QRail with all modules and L-foot attachments and integrates seamlessly with Quick Mount PV waterproof roof attachments for a single-source racking and mounting solution for all roof types.

Quick Mount PV

www.quickmountpv.com

Booth 9311

Contact Us:

rbisolar.com

(513) 242-2051

info@rbisolar.com



The single-source solution for your next solar racking project.

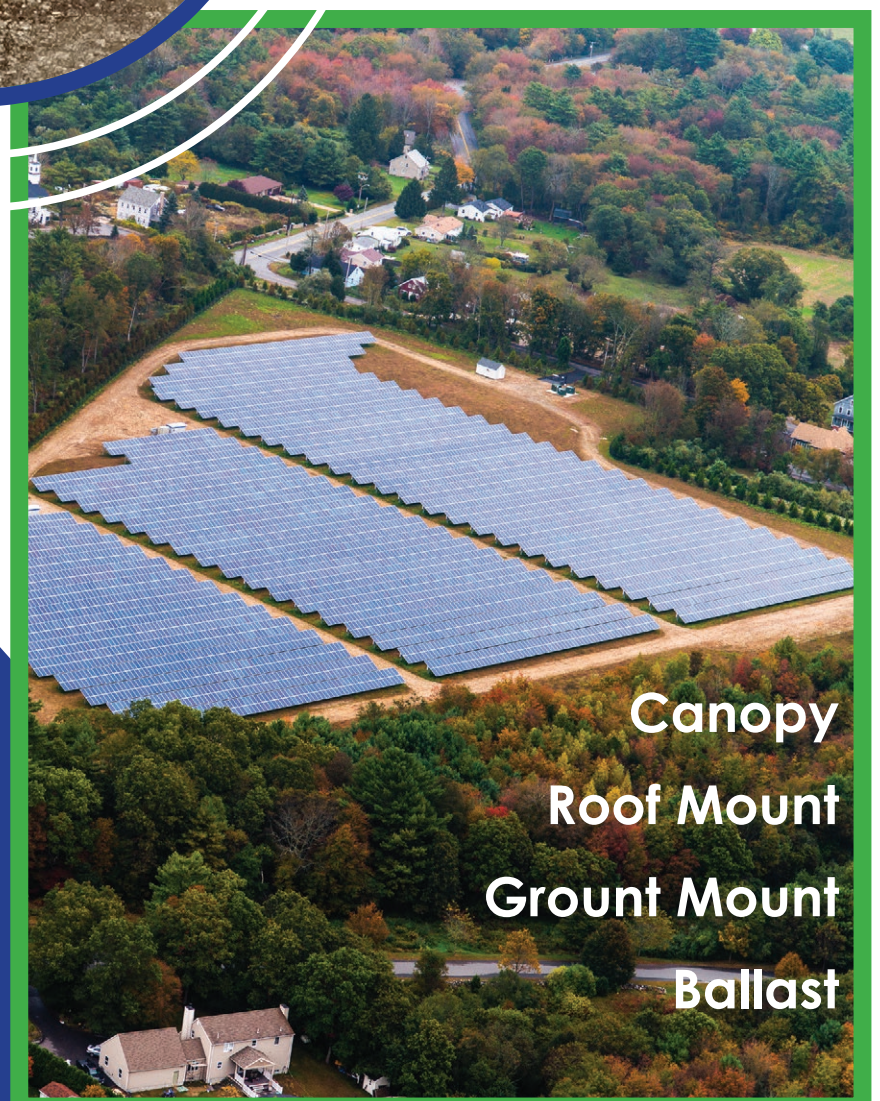

Canopy
Roof Mount
Ground Mount
Ballast



Diaphragms for module laminators

Smartech International will display Steinbach's silicone diaphragm materials. Steinbach diaphragms have a reputation for quality and consistency. Their EVA-resistant Lamibran Diaphragm and three different types of solid silicone are made in Germany in widths up to 3200mm as well as a variety of thicknesses and surface treatments, all backed by Smartech's made-in-USA service.

Smartech International | www.smartechonline.com
Booth 7529



Solar structures & carports

Baja Carports introduces their Braced Single Post Solar Support System. Baja Construction Co. Inc. specializes in designing, engineering, supplying, and installing high-tensile, light-gauge steel Solar Support Structures which exhibit both high quality and cost-effectiveness. They can fully customize their customers' solar projects to provide highly versatile assets to the end users. All of their projects are tailored to optimize specific structural objectives for commercial, municipal, and residential developments.

Baja Carports | www.bajacarports.com
Booth 9511

SOLAR CLIPS



NFI-1701

Brand New rail mounted clip for use with Enphase IQ microinverters



NFI-1306-V90

90° oriented clip intended to secure two USE-2 wires or a single PV wire to standard module frame.



DCS-1306

Designed to secure two USE-2 wires or a single PV wire to standard module frame.

DCS-1307

Designed to secure two PV wires, up to .30" diameter, to module frame.



NFI-1307-V90

90° oriented clip intended to secure one or two PV wires to standard module frame.

NFI-1463

Clip designed to secure a single Enphase trunk cable to module frame.



DCX-2452A

Designed to secure two Enphase trunk cables on to most rail/racking systems.

*For FREE product samples,
 please reach out to Vin Marino
vin@ninefasteners.com or 800.539.3939*



233A South Street | Hopkinton, MA 01748 | 800.539.3939
www.ninefasteners.com



Versatile solar wire management

The BURNDY WILEY ACC-FWT flange securement clips are used to secure a cable tray to PV module frames. The ACC-FWT is made of corrosion resistant 304 stainless steel, which makes it a durable, long lasting, and reliable solution for all environments. The ACC-FWT is easy to install and can be installed onto the module frame and cable tray flanges of various thicknesses. The clips accommodate 12-28 ga galvanized steel or aluminum cable tray, module frames ranging from 1.3mm to 3mm in thickness, and have snake-tongue tabs which securely anchor clips to module frames and cable trays. ACC-FWT flange securement clips are recommended for outdoor use and are a solution for keeping the PV installation neat, clean, and free from ground faults.

BURNDY | www.hubbell.com/wiley/en
Booth 9529



Flexible, versatile tracker technology

The DuraTrack HZ v3 offers revolutionary features, including a single-bolt per module clamp and flexibly linked architecture. The single-axis tracker delivers a variety of efficiencies allowing for quick installation, zero scheduled maintenance, and quick uptime to deliver the best levelized cost of electricity (LCOE).

Array Technologies, Inc. | arraytechinc.com
Booth L9007



Stable and reliable batteries

Battery Systems now offers Centennial AGM batteries which are a representation of stable quality and high reliability batteries. Centennial's AGM sealed construction allows for the battery to provide long life cycles while at the same time being a maintenance-free product with a low pressure venting system. The brand has an ability to deliver high currents without significant drops in voltage.

Battery Systems | www.batterysystems.net
Booth 8031



Quick and simple solar racking solution

Sollega announces the introduction of their new universal slide on clamp. Designed to fit all framed modules, the slide on clamp ships on the FastRack 510 allowing quick and simple installation. Installation consists of positioning the module on the mounted clamps, pulling the clamp until it seats on the flange, and tightening the nut down. The no assembly FR510 is now even fewer parts, speeding up commercial flat roof installs.

Sollega, Inc. | www.sollega.com
Booth 9215

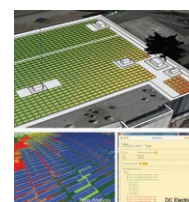

PV design software

SunDAT, from FTC Solar, is an automated 3D PV design software. With a minimum of input, users can lay out PV projects of any size or type, and quickly analyze project details and produce energy generation estimates. Featuring topographical analysis, shading analysis, and detailed electrical design, SunDAT reduces design cycle time. And coming soon, SunDAT Web Service, a powerful design optimization tool featuring a direct web interface and the ability to do hundreds of design iterations on a site in just minutes.

FTC Solar | www.ftcsolar.com
Booth 8429



PV sales and design software

Aurora streamlines and automates the solar design process, empowering solar installers to focus on what matters most—satisfying customers. Whether residential, commercial, or both, Aurora provides the tools needed to go from address and electricity bill to full PV design and sales proposal within 15 minutes. Aurora is used by solar installers across the U.S. and around the world, with over 15,000 installations designed in their software every week.

Aurora Solar | www.aurorasolar.com
Booth 7011



Clean energy for life™



Big & Smart

When it comes to providing big power, **Trojan's Solar Industrial batteries** provide extraordinary performance to enhance the way people live, work and play around the world. Plus, with Trojan's

Smart Carbon™ technology - for partial state of charge (PSOC) applications, you can experience up to a **15% increase** in cycle life.

For over 90 years, Trojan Battery's time-tested line of durable deep-cycle batteries can be counted on day in and day out and can deliver up to **17+ years of life**.*



trojanbattery.com/GoSolar
+1 562-236-3000 | 800-423-6569



*Solar Industrial Line per IEC standards





Reliable PV connectors

Stäubli Electrical Connectors, Inc.'s MC4 connector system is rated up to 1500V UL, 1500V TÜV safety class 0, and is available for 14 through 8 AWG cable configurations. Also available is their in-line fuse PV-K/ILF connector for very low energy loss and heat generation featuring a robust IP68 enclosure. Stäubli Electrical Connectors, Inc. offer custom solutions tailored to their customers' needs.

Stäubli Electrical Connectors, Inc.
www.staubli-alternative-energies.com
Booth 8711



72-cell mono module

The monocrystalline modules of the AXIpremium series are the specialists among the AXITEC solar modules. These high-performance solar modules with up to 360W and efficiencies of 18.55% guarantee high power output. These modules are a solution for maximizing power on commercial projects.

Axitec Solar | www.axitecsolar.us
Booth 7539

ECO
FOUNDATION SYSTEMS INC
THE GROUNDSCREW SPECIALISTS

Stop digging...
Just screw it!

WWW.ECOFOUNDATIONSYSTEMS.COM
SACRAMENTO, CALIFORNIA (916) 709-2551

SIMPLE SOLUTIONS YOU CAN COUNT ON

KB Racking specializes in providing solar mounting systems for commercial rooftops across the world. We manufacture ballasted and anchored solutions for flat roof projects, as well as customized solutions for metal roofs. Email us your project request today with the subject line: 'INT18' for further details regarding our current promotion.

AERORACK 2.0

THE ULTRA LIGHTWEIGHT, RAIL-BASED MOUNTING SYSTEM

EKONORACK 2.0

THE FLAT ROOF MOUNTING SYSTEM WITH ONLY ONE MAJOR COMPONENT

KB RACKING®

1 Atlantic Avenue, Suite 210, Toronto, ON M6K 3E7
sales@kbracking.com | 1.888.661.3204 | www.kbracking.com



Roof-friendly solar pool heating system

Heliocol Solar Pool Heating Systems feature patented individual tube design and mounting hardware combined with one-piece overmolded construction. Heliocol systems are uniquely designed and provide efficiency, reliability, and safety. With a 12-year limited warranty including freeze protection, Heliocol Solar Pool Heating Systems are environmentally safe, maintenance free, and roof-friendly.

Uma Solar | www.umasolar.com
Booth 9114

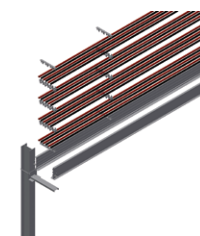

Cable containment system

Solar Snake Max is Snake Tray's new patented cable containment system for utility grade installations. The easy snap together elements allow for code compliant cable separation. Construction cycle times will be cut in half with this innovative approach to managing high voltage cables. Cables install with snap together components, no tools required or field fabrication. Solar Snake Max quickly mounts to any style of vertical pilings or poles and maintains code compliant separation of power cables up to 2KV. Made in the USA.

Snake Tray | www.snaketray.com
Booth 9330

PP PREFORMED LINE PRODUCTS

POWER RAIL™
Commercial Mounting System

MD LD UD XD

A COST SAVINGS RAIL SOLUTION FOR EVERY APPLICATION

- Longer spans and cantilever distances
- Fewer penetrations/attachments
- Lock-in-Place patented RAD™ Bolt
- Single tool assembly
- Designed for high wind/heavy snow
- Integrated grounding

Mounting base bracket attaches rail to structural members

MADE IN THE USA ETL US

preformed.com **800.260.3792**



Mounting system for corrugated metal roofs

The PowerMount for Corrugated Metal Roof Systems is engineered to simplify installation and provide an aesthetically pleasing system. It features a high grade, fully EPDM gasketed mount to help form a water-tight seal with the roof. Cross Stitch Attachment Technology secures the system to the roof with 4 custom screws angled to provide maximum strength and uplift. It also features 3 layers of water protection by utilizing stainless fasteners with EPDM washers. The PowerMount is made from solid 6061-T6 Aluminum and features 2" of adjustment, providing installation versatility. Solar Connections' 6061-T6 Universal PV Cube features a robust design and is compatible with all of their PowerMounts. The Solar Connection Kit with Groundbonding Technology is UL listed and approved.

Solar Connections Intl.
www.solarconnections.com
Booth 9323



Ground mount, ballasted, roof mount, and canopy solutions

RBI Solar is a turn-key solar mounting solutions supplier for ground mount, ballasted landfills, roof mounts, and canopy/carport structures. As a single-source provider for commercial and utility-scale PV projects, all responsibility for the design, engineering, manufacturing, and installation of efficient PV racking systems is completed in-house by the RBI Solar Team. Committed to providing value from conception to completion, RBI Solar's customers receive a cost-effective and durable racking solution for each project site to aide in reducing the overall project costs.

RBI Solar | www.rbisolar.com
Booth 9521



Utility-scale DC-to-DC converter

With over 425MW of energy storage deployed worldwide, Dynapower offers 250kW and 375kW DC-DC converters as well as fully-integrated DC and AC-coupled energy storage systems for commercial and utility-scale solar plus storage. Up to 8 DC converters can be paralleled together. Dynapower's DPS-250 is the first commercially deployed DC-DC converter for utility-scale solar plus storage. Dynapower's DC-DC converters increase project economics and energy production for utility-scale solar plus storage installations.

Dynapower | www.dynapower.com
Booth 8121



Get Out of the Stone Age!

Most rooftop solar racks are designed around ballast blocks or cement pavers. But ballasted rack systems can move around on the roof, grind broken pieces of ballast into the roofing membrane, and leave the building vulnerable to leaks and other roof problems. More important, many buildings cannot accommodate the dead load weight that ballasted systems require.

Move beyond the Stone Age with PowerGrip!

The OMG PowerGrip family of products was designed to reduce ballast from commercial solar racking systems by providing a secure connection directly to the roof deck or structural members. Once secured in place, properly installed PowerGrips minimize rack movement and remain watertight.

Let us show you how a PowerGrip from OMG Roofing Products can help bring your next solar project out of the Stone Age.

Please visit OMG Roofing Products at InterSolar, Booth # 9435 to see the latest PowerGrip offerings!

PowerGrip
ROOF MOUNT SYSTEM

PowerGrip
PLUS
ROOF MOUNT SYSTEM

PowerGrip
Universal
ROOF MOUNT SYSTEM



Superior productivity.
 Superior performance.

800-633-3800

www.OMGRoofing.com OMG PowerGrip™ is a trademark of OMG, Inc. Copyright © 2018 OMG, Inc. All rights reserved.



Energy storage solutions

Fullriver Battery's energy storage portfolio includes its flagship AGM lines, LiFePO4 storage solutions with high cycling capability, and their SunVault line of Lithium storage products. The newest member of the SV family is the SVL16. A drop-in replacement for any L16 format storage bank. With the SVL16 users can recharge faster, discharge deeper, and cycle longer.

Fullriver Battery USA
www.fullriverbattery.com
Booth 8320



High power producing solar tracker systems

GameChange Solar's single axis Genius Tracker provides high power production and low O&M cost. Additional Owner offerings include the technologically advanced WeatherSmart and PowerBoost. Installers will benefit from advanced design innovations with SpeedClamp, QuikClamp, and pre-assembled components. GameChange Solar also offers fixed tilt pile driven, ballasted ground and roof solar racking.

GameChange Solar
www.gamechangesolar.com
Booth 9421



Modeling the economics of solar and energy storage projects

Energy Toolbase is a software platform designed for modeling the economics of solar and energy storage projects. The SaaS platform is used by more than 1,000 distributed energy organizations in all 50 states to accurately propose any type of project, for any type of customer, using any type of financing transaction. Within the Energy Toolbase platform, there is over 30,000 unique global rate schedules in 600+ utility territories, and they have a team continuously updating residential and complex commercial utility rates and incentives. Their team, with a deep background in solar project development, finance, policy, and utility rate analysis, also creates custom rates within the platform for users. The platform was built and designed by renewable energy developers, to cater to renewable energy developers.

Energy Toolbase
www.energytoolbase.com
Booth 8539



Flexible and versatile utility-scale photovoltaic fuse holders

Mersen is excited to announce the launch of the globally certified HP15FHM32 1500VDC HelioProtection fuse holder series for photovoltaic applications. Designed to global standards, the HP15FHM32 series fuse holders are IP20 ingress protection rated, featuring a finger-safe rotating fuse carrier that accept 10/14 x 85mm gPV fuses, introducing the next level of safety for utility-scale photovoltaic applications. The body of the fuse holder is engineered with UL 94 V-0 material, providing a high flammability rating and durability. The fuse holders also include a lock out/tag out feature as well as DMM probe access. The HP15FHM32 series fuse holders are offered in two variations. The HP15FHM32A features a screw clamp, and the HP15FHM32B features a tool-less CAGE CLAMP. Both are to accept standard PV rated wires with DIN rail mounting, providing added flexibility and versatility for end-use installations.

Mersen | ep.mersen.com
Booth 8121

CAB® Solar Cable Management

Now with Integrated Grounding



Patent Protected www.cabproducts.com/patents



Patent Protected www.cabproducts.com/patents

Greatly Lowers Project Costs
Simplifies Electrical Design
Quick & Easy to Install
Easy Maintenance

CAB® Integrated Grounding System eliminates need to run separate grounding conductor and grounding jumpers to all mid piers. Provides both EGC and GEC. Meets NEC, UL and IEEE standards per 2017 HDR Electrical Report. **ETL Safety Listed by Intertek to UL 2703.**

www.cabproducts.com Call: 814.472.5077

Cambria County Association for the Blind and Handicapped



Solar project developer

ISS develops utility-scale solar farm projects located in over 30 states, with an existing pipeline of 15GW. All ISS projects are between 20 and 200MW in size. ISS has sold over 2.5GW of projects and adds 3 or 4GW of projects to their pipeline annually. ISS is a fully customized developer services provider matching their offerings to the needs of the investor. Depending upon the entry and exit timing for the investor, returns can be achieved up to 500%. ISS will deliver projects to investors at any stage from mid-development to COD.

Innovative Solar Systems, LLC (ISS)
www.innovativesolarsystemsllc.com
Booth 7019



Versatile ground mount system

The Advanced Modular ground mount system is a solution for large commercial and utility scale solar projects. Innovative features like integrated bonding, cable management trays, and UL Certified components reduce electrical costs. Engineered cross bracing, high strength steel, and physical testing on every site makes the Advanced Modular ground mount system a very rigid system. AP Alternatives' shallow helical foundations allow massive versatility with soil issues, including: soft soils, low friction soils, high water tables, shallow bedrock, deep frost lines, and rolling topography all at basically no cost increase.

AP Alternatives
www.apalternatives.com
Booth 9410



True deep-cycle AGM batteries

Trojan Battery will showcase the new SAGM 12 105, a Group 31 size battery recently added to Trojan's Solar AGM line. The Solar AGM line of maintenance-free, true deep-cycle absorbent glass mat (AGM) batteries offer a three-year warranty for stationary applications and are tested to an eight-year design life under IEC 61427 standard for solar batteries. The Trojan SAGM 12 105 is manufactured in the U.S. and is now available. It features a non-spillable design enabling installers to customize the use and position of the batteries in customer applications. The Trojan AGM Solar line was designed for maximum sustained performance and increased total energy output to meet demanding deep-cycling requirements in Trojan's wide range of market applications, including solar home, microgrid, inverter backup, and commercial.

Trojan Battery Company
www.trojanbattery.com
Booth 8220



Innovative PV solutions for wafer and cell technologies

Meyer Burger offers highly efficient solutions for wafer, cell, and module manufacturing. With heterojunction (HJT) equipment in mass production, HELiA tool provides high cell efficiencies of > 24%. The benefits of HJT are reinforced with the latest stringer technology for higher module power, less silver, and pleasing aesthetics. PERC equipment with the newest modular cell passivation tools FABiA and MAiA provide competitive LCOE and are a profitable investment for manufacturing highly efficient solar cells. The new slicing equipment DW291 with Diamond Wire technology incorporates innovative features for high throughput and less silicon kerf. Leading wafer producers rely on the quick and precise wafer inspection equipment HE-WI-08.

Meyer Burger | www.meyerburger.com
Booth 7511



Plug & play, wireless balance of systems

Shoals' combiner-less BLA harness has helped streamline installation while creating between 20 and 60% material savings. The newest addition to this is the introduction of BLM which adds current and voltage monitoring along with autonomous I/V curve measurement. I-V curve measurement provides more information about the performance of a PV module or array than any other measurement method and is coupled with the fastest possible measurement tools. The entire system is plug and play and completely wireless - allowing for maximum functionality.

Shoals Technologies Group | www.shoals.com
Booth L8007



THERE'S A LOT OF LIFE IN ONE BATTERY.



BATTERY ENGINEERING

YOUR RELIABLE OFF-GRID SOLUTION.

PREMIUM DEEP CYCLE FLOODED AND MAINTENANCE-FREE AGM & GEL

ROLLSBATTERY.COM



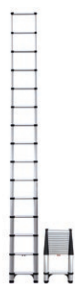

Engineered climbing

The Telesteps 1800 EP is an OSHA compliant telescoping ladder. It opens to 14.5ft, allows a reach of 18ft, and closes to 34in in height. Used by solar installers and contractors, the 1800 EP is easy to carry, use, transport with no ladder racks, and store. It features One Touch Release, pivoting silicone feet, and wide professional steps. Rated Type 1A at 300lbs. All Telesteps products have a one-year warranty.

Telesteps | www.telesteps.net
Booth 9315



Stainless steel wire management

Nine Fasteners' NFI-1307-V90 wire management clip is a 90° oriented clip that mounts directly onto a solar panel's frame (or onto a racking structure in some cases). It is capable of securing 1 or 2 PV wires and is a solution for North/South wire management due to its orientation. This clip is manufactured in the U.S. with a rolled outer edge for maximum wire safety and is UL Listed for use within solar installations.

Nine Fasteners, Inc. | www.ninefasteners.com
Booth 9311



MBarC CONSTRUCTION

THE STRENGTH BETWEEN SUN AND SHADE

MBarC Construction has over 380MW of installed solar structures and offers a rapidly growing catalog of solar carports, canopies, groundmounts, trackers, and DSA-approved structures.

VISIT US AT BOOTH #9217

JULY 10-12, 2018 | MOSCONE CENTER SAN FRANCISCO | MBarCOnline.com | 760-744-4131



connecting solar business | NORTH AMERICA



Clean, low-cost energy storage

The Energy Warehouse (EW) is a flexible long-duration energy storage system that safely and effectively addresses a broad range of energy and power applications at a low Levelized Cost of Storage (LCOS). The system utilizes earth-abundant iron, salt, and water for its electrolyte and simple materials for battery components. It's environmentally safe, with a life span of 25+ years with no capacity fade. As an energy storage solution for 4+ hours duration, this iron flow battery system helps companies choose a long-duration battery solution which is a low-cost viable alternative to lithium-ion batteries.

ESS, Inc. | www.essinc.com
Booth 8129



MORE CHOICES, MORE VALUE.

WHAT'S IN YOUR LAMINATOR?

Let **Smartech** help you find the best diaphragm for your laminator:

- Seamless widths up to 3500mm
- Three different durometers + Steinbach's EVA-resistant Lamibran®
- Textured or smooth surfaces

Lower your production costs by choosing quality **Steinbach** materials.



SMARTTECH

SmartechOnline.com
704 362 1922





Cellular communication with built-in Rule 21 Phase 2 compliance

All exporting inverters and energy storage systems (DER devices) must be compliant with CA Rule 21 Phase 2 secure communication requirements by February 2019. The regulations require every DER device to store its own individual digital private key and certificate. The certificate must be digitally signed by a yet-to-be-named entity designated by the SunSpec Alliance. Wivity works with manufacturers like Zoom Telephonics and Sierra Wireless to bundle Rule 21 Phase 2 compliance directly into the communication component. A DER device manufacturer only needs to call a single API (one line of code) on the communication component achieve compliance.

Wivity, Inc. | www.wivity.com
Booth 8721



Integrated power conversion station

HEM-US Power Station is the latest addition to Power Electronics product family. HEM-US combines advantages of both String and Central Inverter Topologies, while providing a complete Power Conversion Station including internally connected DC Disconnection, Inverter, MV Transformer, MV Switchgear, and Aux. Power in a single cabinet. HEM-US is UL1741SA certified and designed to meet NEC2017 Requirements for both PV and ESS applications. 2.0MW to 3.5MW Inverter is built on field replaceable 6 power modules. Filterless air cooled design with dry type transformer provides savings in O&M, while rated output at medium voltage provides protection and a reduced system cost.

Power Electronics
www.power-electronics.com
Booth 8229

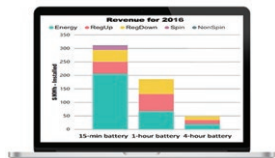

Decision analysis tools

Ascend Analytics provides the energy industry with analysis tools which enable optimal decisions from the next hour to the next decade and beyond. Their enterprise-ready analytic platform provides for integrated physical and financial decisions. The BatterySimm valuation tool identifies configurations and operating strategies to maximize value for battery storage projects. BatterySimm finds the most cost-effective battery configuration for a given node or utility system, and discovers the optimal dispatch strategy by co-optimizing between energy and ancillary services. BatterySimm's advanced algorithms help developers, investors, and utilities define and implement strategies to co-optimize the joint value for both energy and ancillary services markets. It has three different modules to maximize project value through any point of the project life: optimal sizing for energy cycling capabilities and duration specifications; value projects under both perfect and imperfect foresight of energy and ancillary service prices; and determine optimal operating strategies for ISO bidding and integrated utility operations.

Ascend Analytics
www.ascendanalytics.com
Booth 8247



Re-visualizing building methods

Groundscrews are a replacement for concrete pier footings. They offer an extremely fast and strong foundation system in almost any substrate, including rock, and can be installed quickly, with racking being installed simultaneously. Installers can double ground mount production with zero increase in overhead and labor. Groundscrews provide for easy on-site testing, and with less required man-power, a 4-day installation can be completed in 4-hours.

Eco Foundation Systems | www.ecofoundationssystems.com
Booth 7130

Introducing QRail™

It Just Clicks.

Install rooftop solar faster and easier than ever with Quick Mount PV's new QRail Series featuring QClick and QSplice technologies. QRail works seamlessly with Quick Mount PV's industry-leading waterproof mounts for a cost-effective, single-source racking system.

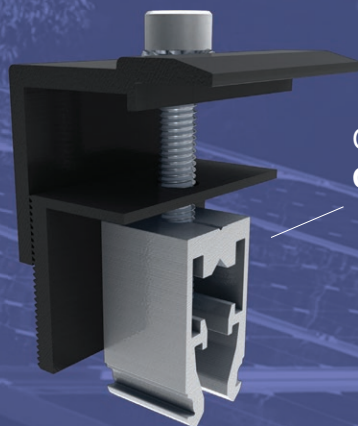

QRail module clamps with patented **QClick Technology™** simply snap into place.



QSplice™ tool-free bonded splice installs in seconds.

Quick Mount PV®

quickmountpv.com | 925.478.8269



Wind Is Going Mainstream in Europe

Global valuation to exceed \$170 billion

by Satarupa De

With prices of renewable energy systems continuing to drop, and environmental concerns growing, the wind energy market is indeed turning out to be promising ground for potential investors. The Vindeby project, recognized as the world's first offshore windfarm, began its operation toward the end of the last century, with a turbine capacity of just 0.45 MW. More than two decades later, the humongous expansion of the wind energy industry clearly supports 2016 estimates, which claim wind to have held a global market share of more than \$70 billion. These promising numbers have led to increasing investment by oil and gas giants, with an aim to exploit maximum opportunities of the wind industry.

Europe is expected to stand as a strong avenue for global market growth

Europe undoubtedly has been one of the most forward thinking regions in the global wind energy industry; it's projected to maintain its supremacy over the coming years. Several factors have contributed to this regional growth. The foremost of these is the financial backing by both private and government entities. In 2017, the European Commission, under its flagship framework program Horizon 2020, invested almost \$17.83 million toward integrating advanced monitoring technologies in offshore wind farms, in an effort to reduce excessive operational and maintenance costs. The Renewable Energy Directive, by the European Union, deals with the overall production and promotion of energy from renewable sources among EU countries. According to the policy, the directive has set a target of 20 percent renewable energy integration in the regional energy matrix by 2020, with wind power at over 200GW installed capacity. With stringent regulatory groundwork instituting a carbon-free environment, along with initiatives geared toward clean energy adoption, Europe has established a strong foothold in global wind.

According to recent reports by Wind Europe, the European Wind Energy Association, the region is on its way to install wind capacity at an average rate of 12.6 GW each year, up to the year 2020. This comes on the heels of Europe's plan to cover almost 16.5 percent of regional

electricity demand from wind energy by 2020, and 30 percent by 2030. Reports predict the major chunk of these developments among six countries: Germany, France, UK, Spain, Netherlands, and Belgium.

- The Netherland government approved a bid for an offshore project that is claimed to be the cheapest of its kind. A consortium has reportedly received this 700 MW capacity contract at Netherland's lowest strike price ever: €54.50/MWH. The Dutch government was awarded a similar contract for the Borssele I and II wind areas, in a bid of 72.70 euros/ MWH. Denmark even set its own record in a November 2016 auction, with a winning bid of 49.90 euros/ MWH. This represents a nearly 50 percent drop from 2014 levels. The cost competitiveness of renewable energy systems, and resulting downward trend of bidding price, has helped the wind energy market proliferate.

ACCC[®]

The World's Most Efficient High-Capacity Low-Sag Conductor

- Increase Line Capacity
- Mitigate Thermal Sag
- Reduce Line Losses

Over 60,000 km at over 550 projects in 50 countries

For More Information please contact:

CTC GLOBAL

Phone: +1 (949) 428-8500
 Web: www.ctcglobal.com
 E-Mail: info@ctcglobal.com

VERIFIED
 BY CTC GLOBAL SERVICES
 • REDUCED LINE LOSSES
 • REDUCED CO₂ EMISSIONS

ACCC[®] is a registered trademark of CTC Global Corporation

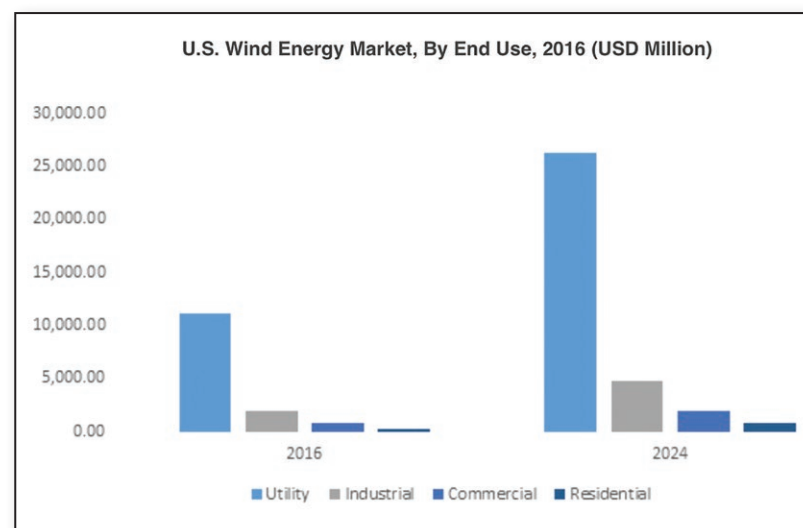



- Germany is also working to establish its share of the Europe wind energy market. In an April 2017 German auction, the average strike price for wind energy projects was reported to be far lower than expectations; the pace of the decline is worth noting. In fact, some of the bids did not require any subsidies, and were won instead at wholesale electricity prices. At this rate, the Dutch government anticipates that, by 2026, the regional offshore auction will require no subsidies at all.

With a maturing supply chain, high levels of expertise, and increased technological intervention, Europe wind energy market size is forecast to observe a double-digit growth rate of 10 percent over 2017-2024.

Other regions are taking note of Europe's significant progress in the competitive landscape, employing their own rigorous efforts toward building supportive regulation for clean energy. China, under its 13th Five-year plan, has claimed that their national offshore wind power would scale up to 10GW of capacity by 2020. Some of the U.S.-based projects are also advancing at an appreciable pace, with a prediction of over 17GW installed by 2024.

Overall, fast paced growth, healthy regional investment, falling component prices, and technological interventions, are some of the major factors expected to drive the global wind energy market. Researchers are scrupulously planning to take maximum advantage of upgraded technology, such as incorporating advanced turbine models, in an effort to curtail the overall generation tariff. With the globe envisioning a carbon-free environment, and the unrelenting march by regional governments to meet this goal, the profitability quotient of wind energy market is bound to witness major gains in the future.

Satarupa De is an engineer who develops content for Global Market Insights. Global Market Insights Inc. is a global market research and management consulting company catering to leading corporations, non-profit organizations, universities and government institutions.

Global Marketing Insights
www.gminsights.com



Wind turbine ice detection

Phoenix Contact's new wind turbine ice-detection system reduces power production loss and increases safety. The self-powered sensors used in this system transmit ice thickness and temperature information wirelessly from blade surfaces without drilling or wires. A single receiving unit is installed in the turbine and receives information from sensing units, which are distributed over the blades' surface. These sensing units are easy to install during regular blade inspections. Detection in a stopped rotor state allows automatic restart to minimize power production loss. The system also measures the direct surface temperature, ensuring precise heating control with blade de-icing systems. The Phoenix Contact wind turbine ice-detection system is suitable for new and retrofit applications and does not require integration into the wind turbine controller.

Phoenix Contact
www.phoenixcontact.com/wind



Safe sampling of transformer oil

RESA Power, LLC has introduced the Sample Guard enclosure for cabinet style transformers. Sample Guard enables safe access to oil sample and nitrogen service lines by relocating them to an enclosure mounted outside the transformer. Technicians can pull oil samples and service the nitrogen blanket with zero risk of Arc Flash. Sample Guard enclosures are easy to mount and arrive with the hardware necessary for installation. The exterior has a NEMA-rated powder coated finish that will last for years in various types of weather. Lead time for the enclosures is two weeks.

RESA Power, LLC
www.resapower.com

Complete Your Wind Projects with Nordic Products



35kV 600Amp Sectionalizing & Splice Cabinets



Chuted Box Pads for GSU Transformers



NORDIC FIBERGLASS, INC.

Quality Products for the Electric Utility Industry

P.O. Box 27 Warren, MN 56762 Tel: 218-745-5095 Fax: 218-745-4990 www.nordicfiberglass.com



Automatically Lubricating Bearings in Wind Turbines

by Kevin Witbrodt

Whether grease or oil, lubricant in wind turbines works to prevent wear and damage between a bearing's rolling and sliding contact surfaces. It reduces friction and heat generation, helps protect against corrosion, and keeps out contaminants. On the other hand, the wrong lubricant (and/or improper lubrication-related practices) can jeopardize bearing performance and service life.

How can wind farm operators avoid lubrication issues?

The right lubricant should always be supplied in the right quantity, at the right time. But lubrication points may be difficult to reach, or inaccessible (perhaps placing maintenance staff in harm's way). In these cases, over- or under-greasing will always be a possibility, lubrication intervals may be sporadic or ill timed, and contaminants may be introduced.

A better alternative can be found in automatic lubrication systems, which are engineered to dispense precisely controlled amounts of the correct lubricant at pre-set intervals. These various systems can effectively safeguard against wear, damage, and premature failures. Ultimately, they enable bearings to perform to their rated capacity at all critical points in a nacelle.

Profiles of System Technologies

According to industry averages, up to 20 percent of the time involved when servicing a turbine is spent on re-lubrication - technicians crawl around in the cramped nacelle and hub of each turbine, and grease lubrication points (from 10 to more than 80) with several different greases. Yet, 36 percent of all premature bearing damage has been attributed to poor

lubrication-related practices. In the worst case, improper lubrication can bring a turbine to a standstill.

When wind turbines go down, the resulting unplanned shutdowns and time-consuming maintenance fixes can exact a heavy toll: exorbitant crane mobilization expenses, lost energy production, soaring costs per kilowatt-hour, and delays in obtaining replacement parts - especially in an industry where demand for necessary components routinely outstrips supply. Anything that prevents a service trip will help boost overall wind turbine ROI (Return on Investment).

Decision-making for the most appropriate lubrication system will depend, in general, on the application, and in particular, on a range of other parameters. These parameters include the operating conditions (variations in the operating temperature and lubricant viscosity), accuracy requirements for lubricant quantities, turbine system geometry (size, dimensions, and symmetry), and monitoring demands, among others.

Centralized lubrication systems can be applied to all bearings at a turbine's rotor shaft, blade pitch, and azimuth positions, as well as non-rotating applications inside the turbine. Stationary systems can supply grease accurately to main shaft, generator, blade, and yaw bearings. For the rotating blade bearings, lubrication systems can be equipped with a follower plate.



THINGS AREN'T ALWAYS THIS PRETTY
WINDBLADE REPAIR TRAINING
Classes fill up fast - ENROLL TODAY!

ABARIS
TRAINING

+1.800.638.8441 • www.abaris.com
 Leading the World in Advanced Composite Training Since 1983!

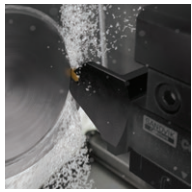

Facing the grooving challenge

CoroCut QF is a new concept from cutting tool and tooling systems specialist, Sandvik Coromant, that has been developed exclusively for face grooving. Designed to deliver reliability and process security, even when machining deep and narrow face grooves, CoroCut QF also provides enhanced accessibility to awkward features. The additional characteristics of CoroCut QF that boost process stability include a new version of the axial-mounting CoroTurn SL head. Use of SL heads means customers can utilize CoroCut QF on damped Silent Tools boring bars for stable, high-quality internal face grooving with increased accessibility to difficult to reach features. CoroCut QF is available in cutting widths of 3mm and 4mm (0.118 and 0.157 inch), four grades (GC1105, GC1125, GC1135 and GC1145) with -TF geometry for deep face grooving. Tailor Made service is also available which makes it possible to build an optimized tool with the exact cutting depth and diameter range required for a specific component.

Sandvik Coromant | www.sandvik.coromant.com

System technologies include:

- **Single point automatic lubricators.** These inject the precise and correct amounts of contaminant-free grease, and often will be used for the re-lubrication of pitch bearings and other bearings in moving parts. They inherently minimize the risks of over- or under-greasing, and can supply lubricant 24/7 for periods up to a year, as governed by a pre-set automatic timer.
- **Single-line lubrication systems.** In this centralized configuration, a central pump station automatically delivers lubricant through a single supply line to a lubricant metering device. Each metering device serves one lubrication point, and can be adjusted to deliver the precise amount of required grease or oil. A single-line system can pump long distances and within a wide temperature range. Components in corrosion-resistant designs will especially benefit offshore applications.
- **Progressive lubrication systems.** These dispense small measured amounts of lubricant at frequent and intermittent intervals. The grease flow created by the system's pump is proportioned by progressive metering devices, and distributed to each bearing according to need. Metered quantities of lubricant are fed progressively in predetermined ratios, from master feeders to the lube points. The lubricant does not leave the respective feeder until the preceding one has discharged its volume.



If a lube point does not receive any lubricant, regardless of the reason, or if a secondary feeder is blocked, the entire lubrication cycle is interrupted, and the system provides a signal to alert operators to the problem. Integrated system control and monitoring is another plus for both progressive and single-line lubrication systems.

Guidelines for Success

When planning to install an automatic lubrication system inside a wind turbine, these guidelines can help:

- Determine the number of lube points
- Choose the proper lubricant for the temperature, speed, and load conditions
- Calculate appropriate dispense rates and quantities for the application
- Choose pumps consistent with the type of actuation and system capacity
- Consider monitoring as an integral requirement for the lubrication system

Close attention should always be paid to the specific type of lubricant required for the turbine main shaft, yaw, and blades. There is no "universal" one-size-fits-all lubricant solution for every application. The proper grease will provide proper lubrication whether the turbine is operating or in standstill mode, onshore or offshore, or in extreme temperatures or conditions.

After an automatic lubrication system is up and running, measurable benefits can be realized at every turn:

- No more over- or under-greasing
- Lubricant consumption can match requirements
- More informed and timely lubricant purchasing decisions can be made
- Lubrication-related breakdowns can be reduced
- Turbine productivity, reliability, and availability can be improved

It's never too late. For existing equipment in the wind turbine aftermarket, generally populated with older and/or smaller machines, operators can take advantage of the latest advanced technologies by upgrading their lubrication programs.

One last piece of advice: partnering with a knowledgeable specialist, with relevant experience and expertise, can help implement best lubrication practices on your wind farm.

Kevin Witbrodt is an Application Engineer at SKF USA Inc., a global supplier of bearings, seals, lubrication systems, and maintenance and reliability technologies and services.

OLYMPUS®

The Portable, Powerful Videoscope

LED Illumination:
Twice as bright as its predecessor (IPLEX UltraLite)

Interchangeable Illumination:
Easily switch between LED, UV, and IR

60 Frames-Per-Second:
Smooth, clear video, even when recording moving objects

New
IPLEX® G LITE
Ultra-Portable Videoscope

Contact your local Olympus sales representative or visit:
www.olympus-ims.com/iplex-g-lite

Olympus offers rental equipment in the US.
Call 24/7 at (281) 922-9300.

Olympus and IPLEX are registered trademarks of Olympus Corporation.

Finding a Component Supplier You Can Trust

by Jesse Shearer

IT'S TIME TO CALL YOUR SUPPLIER. WHO ELSE CAN YOU depend on when you've lost that high from knowing that all your turbines are up and functioning? If a component is to blame, you need to know who you can depend on to get you what you need, when you need it

Choosing a reliable component supplier you can trust is essential to keeping your turbines spinning. From the smallest component to the largest, your suppliers should be a critical part of your extended team, able to understand your expectations and support your needs.

With all of the choices out there nowadays, identifying a great component supplier can be difficult, especially when you are relying on their products and services to keep your turbines running efficiently.

Before you begin the search, make sure that your entire internal team - from the engineer putting together the specifications, to the purchasing group - all have a clear understanding of the component need. You also need to know how to triage your needs. What's your priority? Is it cost? Maintenance? Customer service? Or all of the above?

Having these clear expectations will make the process run smoother and avoid extra time in your search for the best supplier.

The top five factors to consider:

Quality

This seems an obvious factor when deciding which supplier to work with, but quality can be interpreted differently. Your definition of quality should match your supplier's definition of quality before you can determine if they will be a good fit. A quality product should hold up to your turbine's environment and expectations for lifespan. One way a supplier can help assure you of their quality output is through product testing. Is this something your supplier offers? If not, perhaps it's something they would consider, especially if they are new in the industry, or handling a product without adequate history.

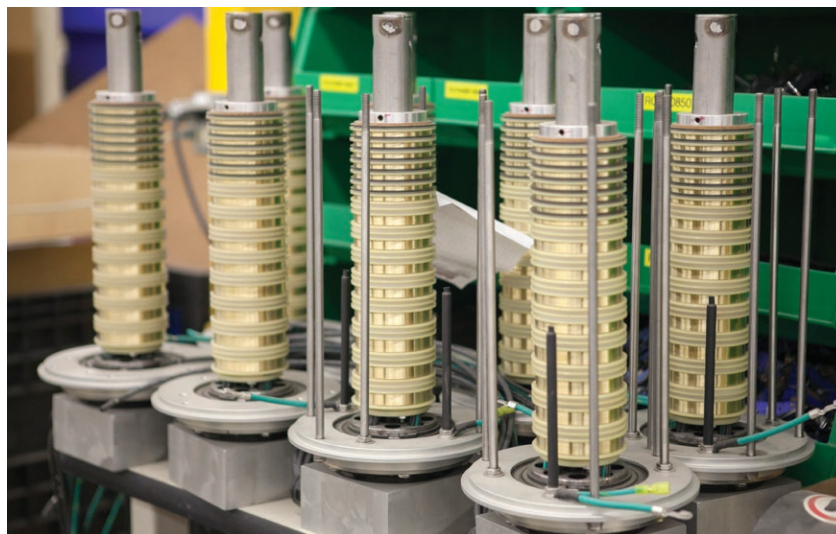
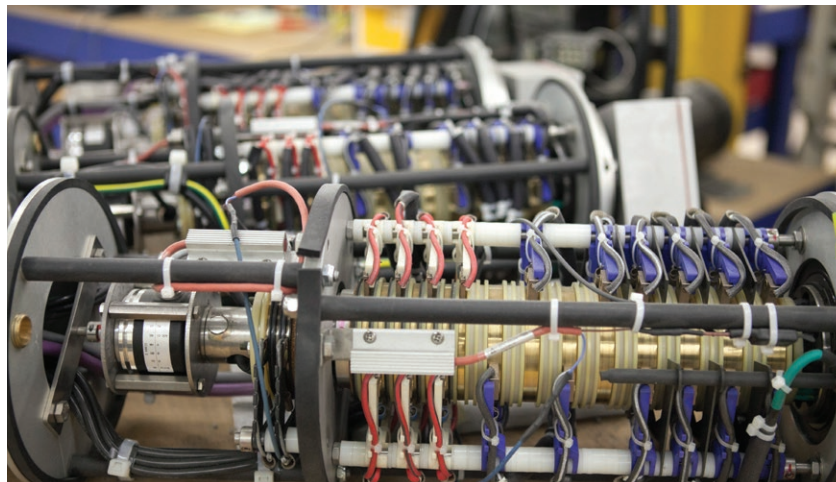

Maintenance

Maintenance is inevitable on any component part, but what is the standard maintenance schedule for that part? Are you currently aligned with that schedule, or are you finding that you need to replace or repair more often?

Asking how often the product needs to be maintained, and the level of ease or difficulty of maintaining that part, should be incorporated into your search requirements for suppliers. Is the product easy to access for routine maintenance? How difficult and expensive is it to replace parts that have worn down? This information sets the expectation for your maintenance schedule, and helps to estimate potential downtime for maintenance needs. If you find that you're maintaining products more often than you should, it's time to have a talk with your supplier. If they're no longer a good fit, look elsewhere.

Customer Service

From general inquiries and quotes, to the design and manufacturing of your product, customer service will most likely be a big factor in your decision to work with a specific component supplier. Response rate and lead times are extremely important, especially in situations when you are in need of a replacement or emergency maintenance. How reasonable is your supplier's lead time? How quickly do they respond to your communications? How is their overall follow-up? Your answers to these questions will be key indicators of whether a supplier is good for your business.

Price

Many things can determine pricing, from materials to shipping fees. Now that you're searching and comparing component suppliers, make sure you're getting the best overall value for the price. Pricing includes not just the product itself, but also the customer service and support provided by the supplier. Understanding a supplier's pricing structure, and looking for that added value, will be key in building a strong and trusting relationship.



WTG1 Ground Solution
solves ground ring **GROOVING**
on Hitachi generators



Adjustability
provides improved
Brush Stability

Double Brushes
Double Contact

Call Kelly: 1-800-999-6322 Ext 31255
Kelly.estrada@morganplc.com

Qualifications

The best practice is to ensure all suppliers meet consistent requirements. This will go far to prevent future issues. When working with the supplier of your most critical components, take the extra time to verify that they are conducting onsite audits to ensure all quality standards are met.

A great supplier will excel in all of the above areas, but ultimately, the best component supplier is one you trust to understand your business, your needs, and your expectations. When you find the supplier that's willing to work alongside your team, to ensure your turbines are running effectively, and help grow your business, your search will be over.

Jesse Shearer is a Slip Ring Engineering Supervisor at United Equipment Accessories, and a 10-year veteran of the wind power and slip ring industries. His main focus has been on hub slip ring technology in large wind turbines.

United Equipment Accessories
www.uea-inc.com



A cost effective emergency tool for evacuating wind turbines

SkySaver Rescue Ltd. announced the introduction of SkySaver-WT, a simple and effective rescue device designed for use by technicians working on wind turbines and other tall structures, such as cranes. The SkySaver-WT looks like a backpack and contains a patented Controlled Descent Device (CDD), which utilizes a redundant centrifugal- and friction-based braking system to lower a turbine technician to the ground at a comfortable two meters per second. The CDD has been designed to function under extreme conditions and withstand prolonged exposure to high heat, flames, cold, water, sharp edges, and can even be operated in saline environments, making the SkySaver-WT a solution for industrial locations. The SkySaver-WT, which is intuitive to use and does not require advanced training, is also valuable in the emergency evacuation of incapacitated technicians, who may not be able to handle the complicated descent using ropes or other contraptions.

SkySaver Rescue, Ltd.
www.skysaver-wtg-safe.com



Wind turbine blade protection

ALEXIT BladeRep LEP 10 is designed to provide protection for the leading edge areas of wind turbine blades from damages caused by rain and particle erosion. This improved product comes in an easy to use two-chamber cartridge allowing for a fast and direct application for simplified on-site repairs. LEP 10 provides benefits including, erosion protection in a single layer, meets or exceeds typical industry standards, user-friendly packaging plus application set for easy handling during on-site repairs, and wide application window allowing all-season repair work. For Mankiewicz and their in-house R&D team, coatings innovations never cease and product improvements are continually introduced to provide protection and durability while offering a simplified application process. The new ALEXIT BladeRep Profile Filler 5 and LEP 10 represent the next evolution in wind turbine coating systems.

Mankiewicz Coatings, LLC
www.mankiewicz.com



Air-driven power unit for high-use applications

Enerpac's new durable air-driven power unit technology is built for high-cycle industrial applications. The DuroTech-Series is well-suited for use in production applications offering a durable dual ram pump with a steel reservoir and protective steel shroud. DuroTech pumps have a long-life and are fully serviceable. The dual ram pump action offers high-oil capacity and automatic pressure control. Additionally, it requires no air lubrication, runs cool, and has reduced noise levels. The DuroTech-Series is available in three air/oil ratio sizes, and offers the flexibility of the industry standard DO3 manifold, allowing customers many options and accessories to create a custom system to fit their needs.

Enerpac | www.enerpac.com

WindEnergy Hamburg

The global on & offshore expo

Hamburg,
25 – 28 September 2018

Over 1,400 exhibitors from 40 countries and some 35,000 trade visitors from 100 countries – that is WindEnergy Hamburg. Be a part of the world's leading expo for wind energy, and find everything that the global wind industry onshore and offshore has to offer.

Register now!

windenergyhamburg.com

 **Hamburg Messe** in co-operation with



Join the Global Wind Summit

 **WindEnergy
Hamburg**
The global on & offshore expo

**Wind^o
EUROPE**

The global on & offshore conference



Ground Ring Grooving

Causes and solutions

by Cole Terwilliger

ELECTRICAL EROSION OF GROUND RINGS

in wind turbine generators is an expensive problem faced by all wind farm owners and operators. Erosion results in loss of revenue due to downtime, cost of replacement materials, and cost of labor for installation. Current remedies include in-situ lathing of the ring, or removal of the ring to be lathed in a shop; both fixes are costly, time consuming, and remove material (life) from the ring OD. This article will discuss the causes and solutions for optimum performance, and extended slip ring life.

Ground ring grooving is caused by arcing between the collector ring and the brush face. "Footprinting", also referred to as "ghosting" or "photo imaging", is the marking of the brush face into the collector ring, relative to the span of the brushes. Footprinting starts to occur when a disturbance forms on the ground ring from vibration, mechanical wear (high spot), bent shaft, or any combination of the three. The disturbance will lift the brush off the ring as it travels underneath

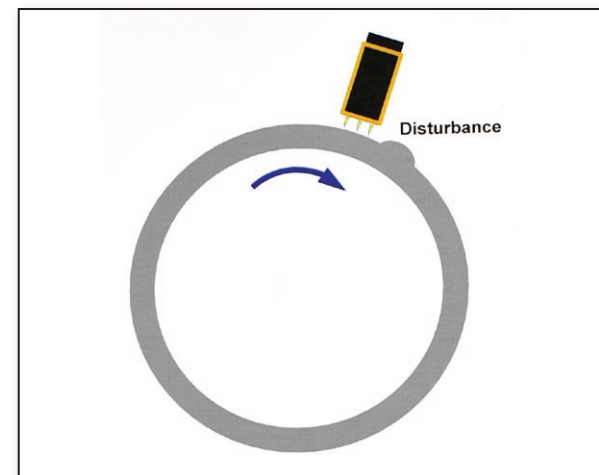

Figure 1:

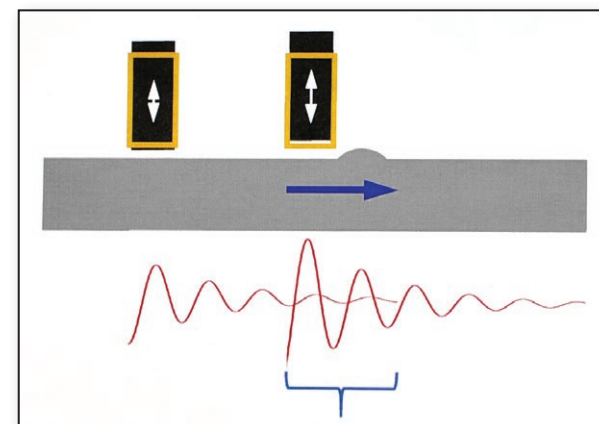

Figure 2:

the brush face, creating an air gap between the ring and brush (Figure 1). The high inductance of the circuit maintains current flow, causing footprinting and arcing. Taking steps to correct footprinting can help avoid further electrical erosion, and extend ring life.

The OEM single pocket ground holders allow only two brushes, covering 40° (1/9th) of the ring. This design attempts to eliminate arcing by having a second brush to carry the current when one of the brushes loses intimate contact with the ring. Unfortunately, the brushes are too close together to solve the problem. The brushes experience a bouncing effect when they are forced back to the ring, from the constant force spring. With this design, the bouncing oscillations of the first brush are very likely still occurring when the second brush sees the disturbance (Figure 2). With a two-brush design spread only 40°, the probability that both brushes leave the ring simultaneously increases significantly.

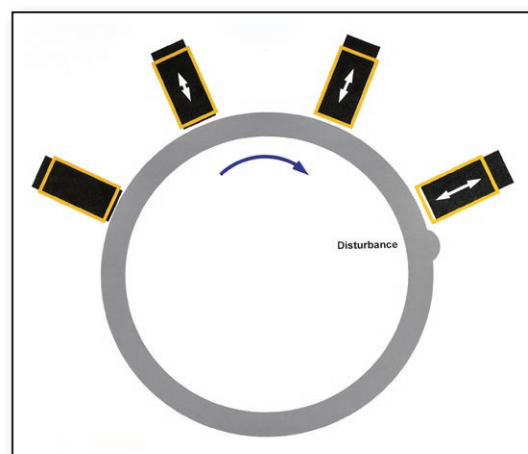

Figure 3:

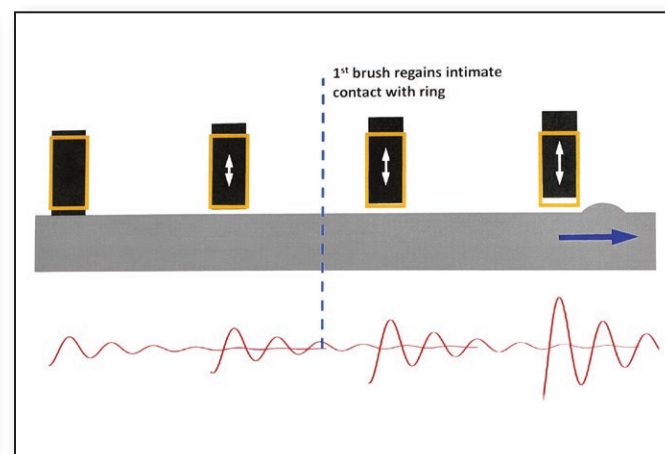

Figure 4:



TP & L
Management Solutions

Making Logistics Easy



By providing logistics management services through every step of the supply chain, **TP&L** ensures your shipments arrive at project sites economically, safely, on time and to the quality standards set by the manufacturer. We currently are storing and maintaining 17,881 components in our yards.



Services and Capabilities:

- Distribution Services
- Inventory Management
- Rail Logistics
- Trucking Logistics
- Indoor/Outdoor Storage
- Maintenance

Check out our distribution centers:
Casper, WY | Garden City, KS | Enid, OK | Grand Forks, ND | O'Neill, NE

tpandl.com • 307-262-6748

FOUR POINTS OF CONTACT

The goal is to ensure at least one brush maintains intimate contact with the ring at all times; replacing the single pocket holders with double pockets that are height adjustable will achieve this goal.

The proposed solution to ground ring grooving is to replace both existing single pocket holders with adjustable, double pocket holders. This doubles the points of contact to 4, and improves coverage and brush stability (Figure 3). Adjacent brushes may still simultaneously lose contact with the ring - the two additional brushes are there to support during such an occurrence, effectively protecting the ring from electrical erosion.

By changing the mechanical parameters of the carbon brush assembly, footprinting and arcing can be eliminated (Figure 4). Two additional brushes in stable, adjustable holders, over a larger arc of the ring OD, will provide three times the coverage of the OEM design. This modification will drastically reduce slip ring damage, save money, and improve uptime.

Once the proper holder design and adjustments are made, using the correct carbon brush material can be an additional key to performance. Brushes should have low friction and low contact drop, as well as be properly treated to survive in harsh environments. Wind turbines can be sited in salty sea air, high humidity environments, or in extreme cold, high altitude, and low humidity environments. Ground rings, like all of the individual components of a wind turbine, are a crucial part of the whole machine. Just as with any machine, the key to keep it running properly is to maintain each piece. By ensuring that brushes, holders, and springs are all properly designed, and correctly adjusted for their operating environment, you can avoid extra downtime and increase overall profits.

Cole Terwilliger works on the application engineering team within the electrical carbon division of Morgan Advanced Materials. Cole has a chemical engineering degree from Penn State, and worked on a process making catalytic converters. Morgan's carbon business includes 35 manufacturing facilities across 5 continents.

Morgan Advanced Materials | www.morganelectricalmaterials.com



Data-driven, engineering-based approach to predictive maintenance

ONYX InSight's hardware-agnostic Fleet Monitor platform brings together data streams from multiple drivetrain technologies and turns them into valuable insight. This insight enables project owners to detect developing failures months before action is required, predict the remaining useful life of components and make informed decisions about where and when to send out inspection and repair teams. In turn, this drives down overall maintenance expenditure and minimizes asset downtime, reducing the levelized cost of energy produced by the turbine fleet. The Fleet Monitor platform forms part of an integrated offering that includes a powerful combination of condition monitoring hardware, software and advanced predictive analytics services.

ONYX InSight | www.onyxinsight.com



Remote visual inspection of wind turbines

Olympus' IPLEX G Lite ultra-portable industrial videoscope enables fast, easy visual inspections of small or difficult-to-access locations. The lightweight, 2.5lb (1.15 kg) videoscope features powerful imaging and measurement tools and its small size and light weight provides for easy one-handed operation. The IPLEX G Lite videoscope incorporates advanced imaging features, including: PulsarPic image processor which reduces halation, balancing exposure and increasing gain quality. A bright LED light source provides improved illumination, and 60-fps frame rate captures smooth, clear video, even when recording a moving object. HDMI video output simplifies the data transfer process, Wider Dynamic Extended Range (WiDER) technology enhances contrast, and users can quickly and easily swap their LED for UV or IR illumination when working in dark environments. The lightweight IPLEX G Lite videoscope incorporates multiple features designed to simplify the inspection process. TrueFeel articulation and a lightweight joystick provide precision control to help users quickly navigate to the inspection area. Smart Video Recording automatically records the last 30 minutes of video inspections to eliminate accidental erasure. Users can also bookmark important video segments and capture still images while recording. An oil-clearing adaptor uses capillary action to provide users with clear images without having to remove the insertion tube to clean the lens. The IPLEX G Lite videoscope is designed to pass U.S. Department of Defense (MIL-STD-810G) four-foot drop tests, it is IP65 Protected against rain, dirt, and dust intrusion, and available with scopes measuring 2m, 3.5m, or 10m long in 4- or 6mm diameters.

Olympus Corporation | www.olympus-ims.com



3MW Smart wind turbine prototype

Goldwind Americas has completed the installation of its GW 3MW(S) Smart Wind Turbine test unit at the UL Advanced Wind Turbine Test Facility located at West Texas A&M University in Canyon, Texas. The scalable 3-megawatt test turbine has an assembled hub height of 130 meters and a blade tip height of 199.2 meters, making it the tallest wind turbine in the United States. Developed by Goldwind, the onshore GW 3MW(S) prototype features scalable rated capacity of up to 3.57MW and a rotor diameter of 136m. The platform's structured design maintains Goldwind's Permanent Magnet Direct Drive (PMDD) turbine technology and incorporates attributes from the GW 1.5 and GW 2.5MW platforms. The GW 3MW(S) features scalable capacity, smart turbine controls, and a structured design.

Goldwind Americas | www.goldwindamericas.com



Blade intelligence

Optimize your turbine assets

- Performance enhancement through WeSense blade monitoring
- Measure true lightning loads with blade-mounted lightning monitoring (LM-S)
- Gauge blade icing to minimize performance loss with self-powered wireless sensors

Phoenix Contact incorporates blade intelligence to raise the total performance level of your wind turbine.

To increase your performance, visit:
www.phoenixcontact.com/wind





4.2M140 and 4.2M148 MW turbines for North American market

Senvion unveils its 4.2MW platform, the 4.2M140 and 4.2M148, based on the company's robust 3.XM series. The Senvion 4.2MW turbines are best suited for low and medium wind sites and are an excellent choice for the US. The 4.2M140 and 4.2M148 type turbines provide a modular approach and technical advancements such as lighter, longer and more efficient rotor blades. The company's dynamic control technologies enable the 4.2M140 and 148 to safely maximize energy production, and adapt to specific to regional requirements, such as noise, site conditions, and grid. The 4.2MW is a direct evolution of Senvion's 3.XM series. These turbines are set to generate a significant increase in AEP, while driving down LCoE. Senvion's highly modular platform, enables delivery of competitive products across wind regimes. The 4.2M140 and 148 are designed for more efficiency, higher availability, and lower transport, installation, and service costs. The 4.2M140 and the 4.2M148 are another milestone in Senvion's modularization and standardization strategy. Coupled with the company's focus on its partnership approach and project specific solutions, Senvion is well positioned to generate high-yields and high returns for its customers. **Senvion** | www.senvion.com



Non-spill, quick-release couplings

Stäubli covers connection needs for all types of fluids, gases, and electrical power. The company offers solutions for connection systems that incorporate techniques and materials that are adapted to marine environments and to remote working. HPX non-spill quick couplings are a solution for heavy duty, high pressure hydraulic applications. A screw locking mechanism with outer ratcheting collar guarantees robust connections, even if subjected to intense pulsating or vibrating cycles. Optional colored alloy caps allow instant visual identification of circuits.

Stäubli Corporation (North America)
www.staubli.us



Durable 30% lighter wrench

Hi-Line presents the Tri-Square Big Wrench from MADI Tools. This latest addition to MADI's lineup of tools includes stainless steel sockets to enhance durability and minimize rusting, and is non-conductive. This 3-in-1 socket wrench fits Lag bolts, "C" clamps and suspension bolts, square nuts (3/4", 1", and 1 1/8"), and lag screw heads (5/8", 3/4", and 1/2" bolts) and the ratchet mechanism offers built-in reversing control. The high-visibility MADI green handle features rubber grip for comfort and secure hold, built-in safety lanyard hole for tethering where required, plus the nonconductive patented handle is also tapered for easy storage in belt or bucket.

Hi-Line Utility Supply
www.hilineco.com



Digital technologies to maximize renewable penetration

Wind operators can ensure stability and reliability, improve system performance, and optimize decision making for their systems using ABB's digital portfolio. These solutions offer a unified, full-spectrum approach to the digitalization of the industry from individual devices to integrated solutions for the wind industry. New technologies extend well beyond wind turbines, including control systems, maintenance, analytics, grid connections, and an electrical integration of power storage and distribution equipment in an e-house, that can be deployed by developers and operators to maximize penetration and use of wind energy. From the control of wind farms to advanced diagnostics that prevent unplanned downtime, ABB Ability based digital solutions include a range of real-time network control, asset management, and portfolio planning solutions that maximize profitability and operate safely by monitoring, operating, controlling, and maintaining mission critical wind investments. Enterprise Portfolio Management (EPM) solutions can provide increased asset utilization and productivity, as well as reduce operating costs. Network Manager Generation Management System (GMS) centralizes wind turbine management as a singular system to monitor, control, and analyze the wind farm portfolio regardless of model or brand. ABB Ability Ellipse connected asset life cycle management (CALM) solution enables wind operators and utilities to optimize asset utilization, drive down maintenance costs and reduce equipment failures and system outages. **ABB** | www.new.abb.com



iOS and Android apps for PLC access

IDEC Corporation announces the release of its WindEDIT Lite app for iOS and Android devices, providing two-way access to its family of MicroSmart FC6A PLCs. With the WindEDIT Lite app, users can monitor any PLC parameter, and change set points and other values. Data register, input, output, timer, and counter values can be monitored and controlled using the standard Dialog Interface. The WindEDIT Lite app also has a custom Dialog Interface which the user can configure to allow only certain PLC parameters to be monitored and controlled. Trending is supported within the app, with users able to plot multiple register points for graphical views. The WindEDIT Lite app runs on any iOS or Android mobile device. Once the app is downloaded to the device, it interfaces to the MicroSmart FC6A PLC via wireless Bluetooth, or Wi-Fi Ethernet for two-way local or remote access. The WindEDIT Lite app provides access to an SD memory card installed in the PLC, so logged information stored in the SD memory card can be easily accessed. The logged data can be viewed, and then attached to a text message or an email, to send to recipients. Logged data can also be pushed to a local or cloud-based database, or to a data storage platform. To provide the required security, access to the PLC via the WindEDIT Lite app needs to be configured in the PLC for each user, with each app user required to provide his or her correct username and password. Read/Write protection is configurable for each designated user, allowing restricted access based on the user's needs; for example, only read and no write privileges. **IDEC Corporation**
www.IDEC.com/usa



PROTECT YOUR INVESTMENT



**PADDING/SHADING EQUIPMENT
AVAILABLE FOR SALE, RENT OR LEASING.**



1.888.997.3687 | RENTALS@WRSRENTS.COM | WRSRENTS.COM | [@WRSRENTS](https://twitter.com/WRSRENTS)



High strength textile chain

The DoNova PowerLash and PowerLift chain is manufactured completely from webbing made of Dyneema. Several layers of the fabric are wound and sewn to form chain links. This textile chain can be produced in any length and is combined with specially developed chain hooks, high-strength shackles, and special tensioner elements. The result is easily comparable with the breaking load and durability of chains made of high-strength steel, but is up to 80% lighter. This makes using the chain much easier and enables the handling of longer lashing chains. **Doleco USA** | www.donova.info



AMERICAN WIND WEEK

AUGUST 5 - 11, 2018

What is AMERICAN WIND WEEK?

American Wind Week is a celebration of how wind works for our country. Elected officials and wind supporters will join together at in-person events and online to show their support for the industry.

Learn more about how you can get involved at
www.americanwindweek.org

Contact windweek@awea.org for more information.



Lubricants and Greases

An important part of the planned maintenance of a wind turbine, proper lubrication will help keep the machinery working well for years. Keeping a wind turbine's gearbox properly lubricated is essential to extending the life of the turbine. Herein we highlight some of the solutions available on the market today...

OILS

SEE AD ON PAGE OBC



Performance by **ExxonMobil**



ExxonMobil

Product: Mobil SHC Gear 320 WT

Application: Mobil SHC Gear 320 WT advanced wind turbine gear lubricant is a fully synthetic gear lubricant designed to protect wind turbine gearboxes operating under extreme conditions, such as extremely low or high temperatures and corrosive environments.

cSt @ 40°C: 320 cSt

cSt @ 100°C: 42.1 cSt

Viscosity Index: 187

Pour Point: -49°F (-45°C)

Flash Point: 492.8°F (256°C)

Key Features:

- Mobil SHC Gear 320 WT features a proprietary additive technology designed to provide excellent protection against common types of wear, such as scuffing, as well as micropitting fatigue;
- The lubricant's synthetic formulation offers extended oil life and drain intervals, helping reduce lubricant consumption;
- Mobil SHC Gear 320 WT, is the first wind turbine oil to be awarded a Conformity Statement by DNV GL, for its reliability and cost saving benefits.

www.mobil.com/wind



Hydrotex

Product: SYN-Nth Gear Oil

Application: SYN-Nth Gear Oil is designed to reduce wear in wind turbine gearboxes for maximum longevity and reliability. Lab-tested and field-proven performance. Guaranteed ISO 4406 cleanliness: 16/14/11.

cSt @ 40°C: 390 cSt

cSt @ 100°C: 43.6 cSt

Viscosity Index: 167

www.hydrotexlube.com

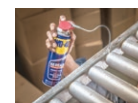

WD-40 Company

Product: WD-40 EZ-REACH

Application: The product has a permanently attached, 8-inch flexible straw that bends and keeps its shape to get the trusted WD-40 Multi-Use Product into hard-to-reach areas. Easily lubricate moving parts, loosen stuck parts, and prevent rust.

Viscosity Index: @100°F (38°C)

Pour Point: <-81°F (-63°C)

Flash Point: 138°F (59°C)

www.wd40.com



AMSOIL, Inc.

Product: Synthetic Power Transmission EP Gear Lubricants

Application: AMSOIL PT Series Synthetic Power Transmission EP Gear Lubes are designed to provide protection for wind turbine and other industrial gearboxes requiring EP protection, such as those found in the textile, paper, steel, cement, plastic, and lumber industries. AMSOIL PT Series Gear Lubes are formulated to meet the listed standards and requirements.

cSt @ 40°C: 326.7 cSt

cSt @ 100°C: 34.8 cSt

Viscosity Index: 151

Pour Point: -36°F (-38°C)

Flash Point: 473°F (245°C)

www.amsoilwind.com

GREASES



Fuchs Lubricants

Product: Gleitmo 585K

Application: Gleitmo 585K is used in Pitch and Yaw Bearing in Wind turbines. It provides the much needed protection from wear and micropitting that is evident in the modern pitch bearing systems.

cSt @ 40°C: 50 cSt

Temperature Range: -49°F to 284°F (-45°C to 140°C)

Dropping Point: >356°F (>180°C)

Oil Type: Synthetic

Thickener Type: Lithium

NLGI Grade: NLGI #2

Oil Separation (40°C for 40 days): <5%

www.fuchsus.com



Motion Industries

Product: CRC Sta-Plex Extreme Pressure Premium Red Grease, 14 Wt Oz

Application: A multi-purpose certified lithium complex grease recommended for many uses including bearings, and all moving and sliding surfaces to reduce friction in extreme environments. Applies for use in industrial mining, metal production, machining, plastic molding, pumps, electric motors, ball and roller bearings, kilns, assembly plants, drying ovens, trucks, automobiles, buses, construction equipment, off-road operations, tractors mowers, reapers, and water pumps.

cSt @ 40°C: 200 cSt to 260 cSt

cSt @ 100°C: 16.5 cSt to 19.5 cSt

Viscosity Index: 85

Pour Point: 5°F (-15°C)

Flash Point: 475°F (246°C)

Dropping Point: 500°F

Soap Type: Lithium

PAO: Synthetic

NLGI Grade: 2

www.motionindustries.com

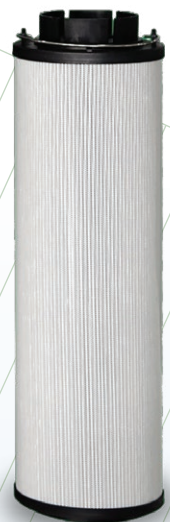

**EFFICIENT,
ECONOMICAL,
RELIABLE**

▶ **1300R Oil
Filter Element**

**WH1300 R010
BN4HC-V-B4-KE50***

**Beta rating:
β1000 @ 12.13μm(b)/10.89μm(c)
Dirt holding capacity: 242.72g**

***R005" with 5μm media also available*

taylor@whfilter.com | 248-997-0233

Filtration

Research shows that 80% of oil related failures and breakdowns are caused by contaminated oil. Preventive oil maintenance is therefore an important factor to ensure optimum equipment reliability and avoid system breakdown. Here are some of the filter options available on the market today...

SEE AD ON PAGE 62



WanHe Filtration, Inc.

Product: WH 1300R Gearbox Oil Filter
Application: WanHe Filtration specializes in premium oil filtration products designed as direct replacements for OEM filters. WanHe's filtration solutions are efficient, economical, and reliable.
Micron rating: 10 Micron (5 Micron options available)
Beta rating: β_{1000} @ 12.13 μm (b)/10.89 μm (c)
Dirt holding capacity: 242.72g
Starting pressure drop: 27.43 hPa (ISO 16889)



Compatibility with fluids: PAO Compatible, PAG Compatible (with Viton seals)
Material: Synthetic
Warranty: Full manufacturer's warranty
Key Features:

- Strict selection of filter media;
- Dedicated customer service;
- Competitive pricing structure;
- Strong field support;
- Customized solutions available.

www.wanhefiltration.com



Hy-Pro Filtration

Product: CFU Compact Filter Unit
Application: Designed specifically for limited space operations, the CFU maximizes power in a minimal package. Use the ergonomic handle to hoist the CFU to provide filtration directly within turbine nacelles or filter straight from atop the barrel to take out contaminants before they can ever reach the equipment.
Micron rating: Media options down to $\beta_{2.5[C]} \geq 1000$, $\beta_1 \geq 200$
Beta rating: Media options down to $\beta_{2.5[C]} \geq 1000$, $\beta_1 \geq 200$

Dirt holding capacity: dependent on configuration
Water absorption capacity: dependent on configuration
Starting pressure drop: dependent on configuration
Compatibility with fluids: Petroleum and mineral based fluids (standard). Options for Skydrol and other specified synthetics.
Material: Aluminum
Warranty: 1-year warranty
www.hyprofiltration.com



National Filters, Inc.

Product: RHY1300SP-19-5G/5SS-V/3-D
Application: Utilizing high quality components, this dual stage filter is designed for wind turbines, such as the GE 1.50 MW. National Filters' elements meet the ISO cleanliness levels wind systems require.
Micron rating: 5

Beta rating: 200/4.5
Starting pressure drop: 305psi
Compatibility with fluids: Compatible
Material: Microglass, steel
Warranty: 1-year warranty
www.nationalfilters.com



Filtration Group - Hydraulics

Product: PulseShield Multi-Layer Filter Elements
Application: Filtration Group's filter elements with PulseShield compression sleeve secures the pleated star firmly to the inner core and guarantees uniform pleat separation for the life of the filter element. The PulseShield compression sleeve combined with up to three Premium Select fiberglass layers increases the dirt holding capacity by as much as 30% in comparison to conventional filter elements.
Micron rating: 1 μm - 25 μm
Beta rating: minimum 200
Dirt holding capacity: depending on retention >15mg/cm²
Starting pressure drop: depending on size, flow rate, viscosity
Compatibility with fluids: PulseShield and PulseShield Pro elements can be used with all standard oils and fuels.
Material: Synthetic: Glasfiber material, plastic outer jacket
www.filtrationgroup.com



ANNUAL CONFERENCE AND EXHIBITION

CALGARY, ALBERTA OCTOBER 23-25, 2018



windenergyevent.ca

MODERN. COST-COMPETITIVE. CLEAN.

Organized by  

The Gray Behind the Green

by Dan Sanchez



Several industries are doing their part in reducing waste, and minimizing their use of fossil fuels by switching to battery-powered vehicles. For example, rental agencies that provide construction, cleaning, and small delivery vehicles to a variety of markets, have seen a greater demand for battery-powered access lifts, cranes, fork lifts, floor cleaning machines, and more. The latest developments in battery technology allow for lower energy consumption, and longer runtime between charges. The shift towards battery powered equipment has helped many industries move to the forefront of the green movement.

In addition to the obvious advantages (zero-emissions and using less fossil fuel), many companies are discovering that battery powered machinery and vehicles are also more cost effective, and can ultimately reduce annual operating costs, and boost profits. While this sounds like a great way to become “greener” on a large scale, there is still some confusion as to which types of batteries provide the greatest benefit to the environment, especially from the standpoint of manufacturing and recycling.

Recycling Lithium and Flooded Lead-Acid

While lithium-ion batteries are gaining in popularity, they can't match the recyclability of lead-acid batteries. The Battery Council International (BCI) has released a study showing that lead batteries have a recycling rate of 99.3 percent¹. This makes lead batteries the most recycled consumer product in the U.S., ahead of commonly recycled products like aluminum and steel. In addition to this remarkable recycling rate, lead batteries are unique in that new batteries are comprised of roughly 80 percent recycled lead battery material. According to a study in The Journal of The Minerals, Metals & Materials Society (TMS), approximately 95 percent of Li-ion batteries are landfilled instead of recycled upon reaching end of life². This is mainly due to the purity requirements of raw materials, which are so high that it is not economically feasible to recover the materials for new battery production.



According to the BCI, lead recyclers undergo some of the most restrictive emissions regulations in the U.S. The process of recycling lead, combined with tough emissions standards, has produced new methods of recycling with reduced emissions that are far below EPA regulations. The BCI also reports that contamination in the air from lead recycling plants has dropped by 99 percent since 1980. A recent study released by the organization suggests that the U.S. lead battery industry also enables more than 95,000 jobs for American workers, and contributed more than \$28 billion in total economic output to the national economy in 2016³.

Sourcing Materials

While striving for greater environmental solutions, battery manufacturers also recommend looking behind the scenes, at how and where the materials for making batteries are sourced. While lead from batteries is almost 100 percent recycled, lithium battery manufacturers rely heavily on raw materials sourced from mines to produce batteries. Due to growing demand for lithium, the sources of these materials are under intense scrutiny. A recent article in the Wall Street Journal, written by Scott Patterson and Russell Gold, highlighted the race to control raw materials for the lithium battery industry. Cobalt is a key component used in manufacturing lithium batteries. Producers are rushing to pull massive amounts of cobalt from mines in the Congo region of Africa. Consequently, there is an effort to secure the area's natural resources, in anticipation of the predicted growth of electric vehicles. Mining companies that use freelance or child labor, operating under poor safety conditions, are attracting human rights groups such as Amnesty International to look into these supply chains.

Not all lithium battery manufacturers source their raw materials from unscrupulous mining operations, but increasing demands mean a surge for raw materials on the open market. Equally troubling is what happens to these batteries once they have reached end of life - most wind up in landfills or lead battery recycling centers, causing fires and explosions.

Hazardous Battery Waste

According to the article in USA Today, lithium-ion battery manufacturers are pleading with consumers not to throw used batteries in the trash or recycling bin. The article states that 65 percent of recent waste facility fires were a direct result of lithium-ion batteries that were tossed in the garbage.

Call2Recycle, a national recycling program funded by battery manufacturers, reported that there's a high possibility of explosions in waste facilities when lithium-ion batteries from electronic devices are included in the garbage. As an example, USA Today also reported that lithium-ion batteries were the cause of a five-alarm fire in a recycling facility in Queens, New York, which burned for two days. A recycling plant in Indianapolis shut down after a fire from lithium batteries, and there was an explosion in a garbage truck in New York City after workers compacted waste that ignited a lithium battery.

In California alone, the problem has reached a point that the state is launching an awareness campaign to get consumers to keep these batteries out of the garbage and out of lead-acid battery recycling centers. In an effort to curb improper disposal of used lithium batteries, some areas are encouraging consumers to put the batteries in a plastic bag and set them on top of their trashcans for pickup. In addition, some retailers such as Home Depot, Lowes and Best Buy, according to USA Today, have recycling centers for used lithium batteries.

While lithium batteries are more widely used in mobile devices and computers, the rental equipment industries are still using mostly flooded lead-acid (FLA) batteries. The reason, according to many equipment manufacturers, is that current lead battery types remain the most cost effective solution for powering these types of vehicles. Although lithium battery packs may provide longer cycle life, experts suggest comparing total life cycle costs between FLA and lithium battery packs with similar energy content (kilowatt-hours); flooded lead-acid battery packs have been shown to provide the most cost-effective solution, at a total of the initial purchase cost and the operational cost per kilowatt-hour.



It's easy to see why many industries continue to use flooded lead-acid batteries - they're easier on the environment and better for the bottom line.

Dan Sanchez is a journalist, author, and media content provider to a variety of energy companies such as U.S. Battery Manufacturing.

U.S. Battery | www.usbattery.com

¹ https://essentialenergyeveryday.com/wp-content/uploads/2018/01/EEE_Sustainable_FactSheet.pdf

² Heelan, J., Gratz, E., Zheng, Z. et al. JOM (2016) 68: 2632. <https://doi.org/10.1007/s11837-016-1994-y>

³ Lead Battery Industry Provides Billions in Economic Benefit, Provides Gateway to Middle Class - Battery Council International February 1, 2018



Nel Hydrogen and Proton OnSite® Merge – Now the World's Largest Electrolyser Manufacturer

YOUR BEST SOURCE FOR ENERGY STORAGE SOLUTIONS.

- Alkaline and Proton® PEM Technologies
- Safe, Clean and Cost Effective
- Grid Management Scaled to Match Any Application

Visit us on-line at www.NelHydrogen.com or call +1-203-949-8697

nel 
number one by nature™

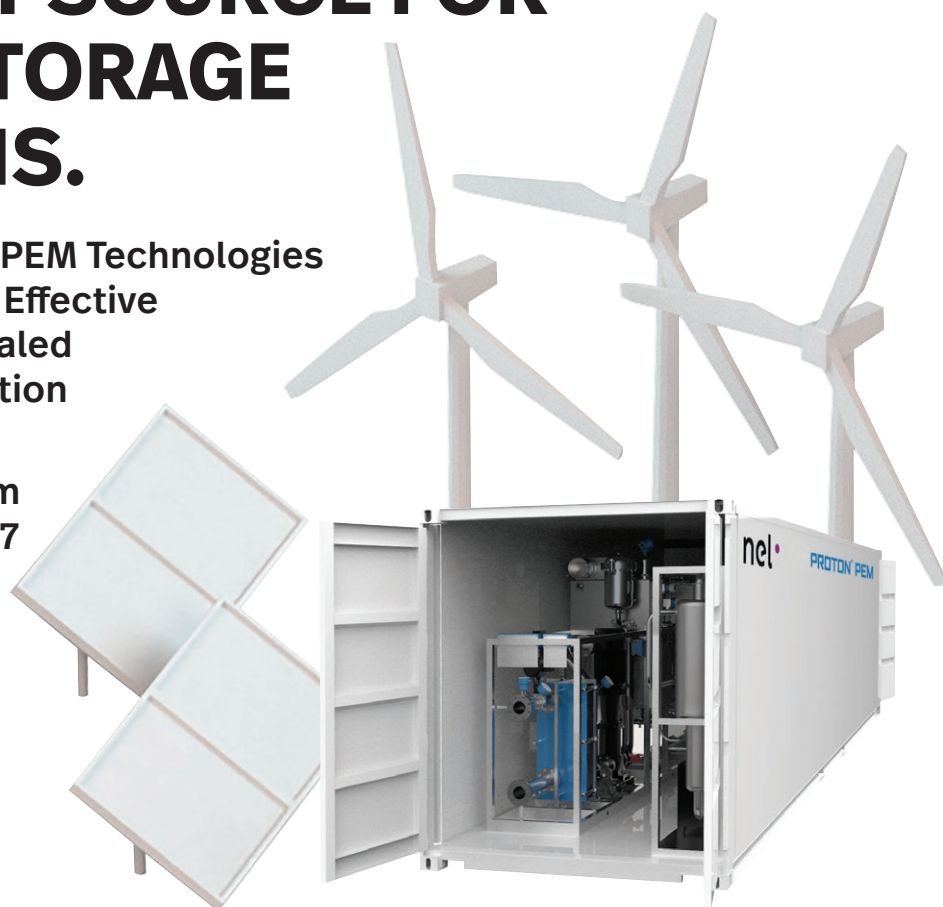



Dangers Associated with Passive Ground Fault Protection and Detection

by Dale Boyd

AS POWER GENERATION EVOLVES AROUND THE WORLD

to meet demand, more smart grids require the storage of excess generated electricity to maximize peak efficiency. Battery storage systems are becoming more widely used. In order to help today's smart grids operate, smart electrical safety equipment is a must. Proper electrical safety doesn't just protect personnel - it helps protect equipment from electrical and fire damage.

For decades, electrical systems classified as critical infrastructure have utilized ungrounded and high-resistance grounded substations. In a single ground fault condition, these system configurations allow processes to continue to operate. In North America, passive three-light bulb indicator systems have been used for many years for ground-fault detection.

While NEC 250.21 (B) permits the use of three-light systems for detection, it should be noted that the NEC is a minimum design standard; ground-fault detection, location and protection technology has advanced significantly in the last 20 years. Since these passive systems are still used, however, it's important to discuss how they work and the typical issues that arise, especially when incorporating newly designed energy storage systems into existing Ungrounded, or High Resistance Grounded substations or facilities.

System Description:

- Passive ground fault detection systems are designed for operation on three-phase ungrounded, or high-resistance grounded systems. These devices will not work on any type of solidly grounded system.
- A traditional three-light ground fault detection system is wired in a "wye" configuration, with the center of the wye connected to ground, rated at the full voltage of the system. For example, a 480-V system requires 480-V pilot lights (which may include potential transformers).

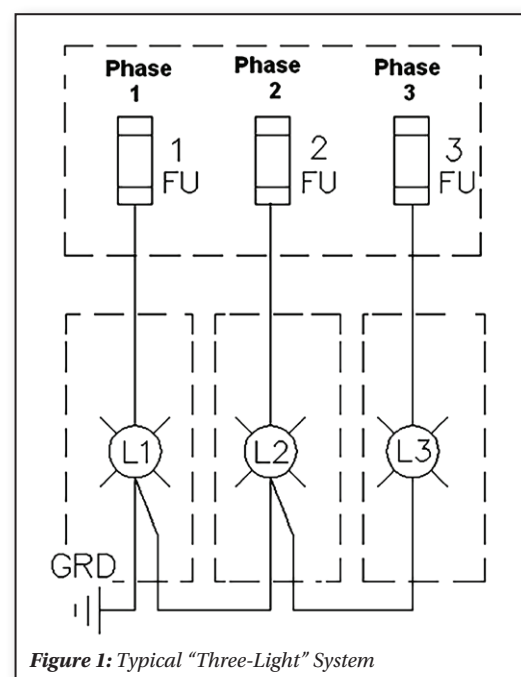

Figure 1: Typical "Three-Light" System

System Operation:

1. According to a study conducted by Rockwell Automation, in normal operation, all three lights will be at approximately 57 percent brightness.
2. When one phase of the power system is faulted to ground, the light connected to the faulted phase will be off. The other two lights will be at full brightness.

For example:

- On a three-phase 480-V system with no ground fault, phase-to-ground voltage is 277 V on each phase.
- If Phase 1 (Figure 1) were to experience a ground fault, the phase-to-ground voltage on L1 would be 0 V.
- The voltage to ground on L2 and L3 would be 480 V.
- If the ground fault was not a "solid" fault, but had some type of impedance (such as in a motor winding), one light would be dim, and the other two would be brighter.



November 6-8, 2018

PASADENA, CA



ENERGY®
STORAGE
NORTH AMERICA

REGISTER NOW!

System Advantages / Disadvantages:

1. A single three-light detector on an electrical system only indicates if a fault is present and in the faulted phase. It cannot help in locating the source of ground fault(s).
2. The three lights are blind to symmetrical faults (two high-impedance faults) on a system. This can lead to a catastrophic situation, with very difficult-to-locate ground faults.
3. Since they have no means of communication, this type of system does not typically notify personnel there is a fault on the system. In this case, fault indication is only provided when a technician observes the lights. With the shortage of manpower in most facilities, this could result in undetected ground faults on a system for extended times.
4. If a ground fault is allowed to remain on a system for an extended period, there is risk that the ground fault could escalate to a phase-ground-phase (or phase-phase) fault, resulting in catastrophic equipment failure. This can occur when a second ground fault occurs on a system. This could present an arc flash hazard, especially if the second fault was caused by personnel contact.

Note: The Industrial Power System Grounding Design Handbook states that 95% of all electrical faults are phase-to-ground faults. IEEE141-1993 Recommended Practice for Electric Power Distribution for Industrial Plants 7.2.2 states "there is no arc flash hazard (on HRG systems) as there is with solidly grounded systems, since the current is limited to approximately 5 amps."

Recommendations:

Solutions to these issues come in many forms. Conversion to high resistance grounding with individual feeder protection is often selected, to help alleviate the transient overvoltage potential inherent to ungrounded systems, and to make it easier to locate ground faults.

Where ungrounded systems are still utilized, insulation monitoring devices can provide critical infrastructure system-to-ground resistance monitoring to detect ground faults, and even allow location of faults while maintaining continuity of service.

As more energy storage applications are being retrofitted into existing systems, safety and reliability of both the energy storage module and the end-user's electrical system must be considered. Failing to do this undermines any advantages of energy storage. These best practice principles should begin during the specification stage of a project – not after a system has been deployed.

Dale Boyd has a Bachelor of Science degree in Electrical Engineering Technology degree from Old Dominion University. He spent fourteen years in the Pulp & Paper Industry as a Project Design Engineer, and several years as Chairman of the Global Power Committee for a major consumer products paper company. He has also worked with various electrical manufacturers; his roles have included power consulting, national accounts manager and regional sales director. Dale is a member of IEEE, and active in the pulp & paper IEEE Group. He has developed power system solutions with many end customers, ranging from electrical distribution system upgrades to ground-fault solutions.

BENDER provides electrical safety equipment to industries worldwide, protecting people, equipment, and facilities, with the latest in electrical safety technology.

Bender | www.bender.org



Off-grid primary power fuel cell solution

GenCell Energy's GenCell A5 is a fuel cell solution which creates hydrogen-on-demand from low-cost ammonia fuel. Designed to provide cost-effective, ultra-reliable power for off-grid and poor-grid telecom base stations, the GenCell A5 fuel cell solution overcomes the high-costs of powering rural telecoms. When compared to using conventional diesel generator solutions over a 10-year period, the GenCell A5 solution can reduce OPEX costs of Tower Management Companies (Towercos) and Mobile Network Operators (MNOs) by up to \$250M across 1,000 towers. Further reducing the OPEX costs for Towercos and MNOs, the new GenCell A5 off-grid power solution requires minimal maintenance. A single 12-ton tank of ammonia provides the GenCell A5 with enough fuel for a year of 24/7 operation. The proprietary GenCell IoT Remote Manager enables remote diagnostics and monitoring of each fuel cell device, reducing the frequency and costs of onsite engineer visits.

GenCell Energy | www.gencellenergy.com



THE DAYS OF A SIMPLY NEEDING AN INVERTER HAVE CHANGED



RIS 30/60



RIS 50



RIS 125



RIS 250



RIS 500



RIS 1000



RIS 2000

Rhombus complete Site Inverter Systems Deliver:

- Maximum flexibility with optional power stages that can be configured in multiple ways
- Integrated VectorStat® site controller that can be configured as a mesh or "hub and spoke" SCADA configuration
- Integrated utility grade meter system Multi-mode, multi-port, utility interactive bi-directional Inverter for on and off-grid connections
- Power converter for distributed energy resources in grid or island mode
- Resiliency designed multi-point communications to remote equipment
- Integrated isolation transformer
- Wide input voltage range
- Direct air-cooled

VectorStat® Integrated Site Controller Includes:

- Feature rich, distributed architecture with industrial grade encryption
- Software platform and databases with industry proven open-source modules
- Persistent key value and time based database which runs on VectorStation™ hardware or VectorCloud™
- Open to customer-designed "applets" for customized applications
- Includes MODBUS, CAN, USB, RS-485 interfaces
- VectorStat® nodes can be connected to disparate equipment and included in network
- UL 1741 SA Certified and SunSpec® compliant



USDA REAP Loans

Fact vs. fiction

by Jordan Blanchard

Loans for renewable energy projects using the USDA REAP (Rural Energy for America Program) are essential to increasing our energy independence. REAP loans have long terms, low interest rates, and are fully amortized, with no calls or balloons. Government guaranteed loans sometimes get a bad rap when lenders who are not experts at USDA lending do a poor job. An inexperienced lender can cause the process to be lengthy and frustrating, which often leads to misinformation about the loan program.

Read on to learn some common myths surrounding USDA financing, as well as how to carry out due diligence on your lender, and navigate potential pitfalls. Regardless of state or U.S. territory, solar developers should consider USDA financing as a viable option for renewable energy projects. Here's what to keep in mind:

USDA REAP loans are slow. FICTION. Look for a bank that has an experienced team who can navigate the USDA application and approval process. Many banks offering USDA products use outside third parties to compile application and loan information. However, if you choose an institution with an internal staff, with years of industry experience and expertise in USDA programs, the process can be significantly expedited.

USDA loans require too much paperwork. FICTION. All loans, regardless of type, require paperwork. Look for a bank with a streamlined and automated loan process. You will need an institution that is able to prepare all the USDA application documentation in an efficient manner, and submit it to USDA for approval, so the process is seamless for the borrower.

USDA loans pose no risk to the originating bank. FICTION. The USDA guaranty ranges from 60 to 80 percent, leaving a credit risk of up to 40 percent. In order to ensure your project has a successful track record, find a lender that understands the renewable energy industry, risks, and the USDA requirements.

USDA interest rate, terms, and conditions are attractive. FACT. Research lenders that offer flexible terms with longer amortizations than standard lenders, and consider rate locks as an option. You also want to determine if the lender can fund utility scale projects from 1-25MW, and can work with multi-site bundles of varying sizes.

USDA loans have fees. FACT. Yes, REAP loans have a guarantee fee of 1% of the guaranteed amount of the loan (60 to 80 percent of the total loan amount). USDA receives 100 percent of this fee. This fee is much lower than fees in other government loan programs.

I can get the same USDA deal at my local bank. PROBABLY NOT.

Local banks value your relationship, but may not have USDA experts in-house. This is where research is paramount in finding the best deal possible in every way – lowest rate, longer terms, speed, and responsive and knowledgeable people.

USDA servicing is burdensome. FICTION. There are banks that maintain a close relationship with the borrower after closing, and handle all the USDA required financial monitoring. Select a lender that can bridge that relationship throughout the life of the loan, to ensure your project is geared for success.

Jordan Blanchard is general manager of the renewable energy team at Live Oak Bank. He's responsible for deal structuring, pricing, team leadership, marketing strategy, and all aspects of loan production. Prior to this role, Jordan was managing director of Live Oak's SBA 504 Secondary Markets where he co-founded a closed-end mutual fund that purchased small business commercial real estate loans from banks and non-bank lenders. He previously held leadership roles at Community National Bank, Temecula Valley Bank, and Excel National Bank. Jordan received a B.S. in business administration and finance from San Diego State University.

Live Oak Bank | www.liveoakbank.com



ENERGY STORAGE INTERNATIONAL

September 24-27, 2018

Anaheim Convention Center | Anaheim, CA

The largest energy storage event in North America

From energy storage business models, to microgrid configurations

Energy Storage International, part of North America Smart Energy Week, brings together a variety of energy professionals from solar, wind to those interested in EVs and more. There are a variety of educational opportunities, from technical experience geared for engineers, to an energy storage 101 class that focuses on giving you a background of how energy storage works, and case-studies on how to successfully grow a storage component to your business.

POWERED BY



Co-located with



Register and learn more at energystorageinternational.com

JULY

- 10-12 **Intersolar North America**
Moscone Center – San Francisco, CA; www.intersolar.us
- 10-12 **ees North America**
Moscone Center – San Francisco, CA; www.ees-northamerica.com
- 17-19 **2018 Plugvolt Battery Seminar**
Plymouth, MI; www.plugvolt.com

SEPTEMBER

- 05-06 **Wind Power on Capitol Hill**
Washington, DC; www.awea.org
- 11-12 **Wind Resource & Project Assessment Conference**
Sheraton Austin Hotel at the Capitol – Austin, TX; www.awea.org
- 13-14 **Offshore Wind Executive Summit**
Houston, TX; www.offshorewindsummit.com
- 21-22 **Microhydro System Design and Installation Workshop**
Appalachian State University – Boone, NC; www.energy.appstate.edu
- 24-27 **Solar Power International 2018**
Anaheim Convention Center – Anaheim, CA; www.solarpowerinternational.com

OCTOBER

- 01-02 **Wind Energy Finance & Investment - East**
New York, NY; www.awea.org
- 05 **Wind Energy Finance & Investment - West**
San Francisco, CA; www.awea.org
- 10-11 **Horizon18**
Boston Convention and Exhibition Center – Boston, MA; www.awea.org
- 14-17 **GRC Annual Meeting & Expo**
Reno, NV; www.geothermal.org/meet-new.html
- 16-17 **Offshore WINDPOWER Conference**
Hyatt Regency Washington on Capitol Hill – Washington, DC; www.awea.org

NOVEMBER

- 06-08 **ESNA 2018**
Pasadena, CA; www.esnaexpo.com
- 08 **Renewable Energy Grid Forum**
Grand Hyatt – San Francisco, CA; www.renewablegridforum.com
- 13-15 **Wind Energy Fall Symposium**
Colorado Springs, CO; www.awea.org
- 28-29 **Companies vs Climate Change**
Adrienne Arsht Center – Miami, FL; www.solveclimatechange.com

JANUARY 2019

- 23-24 **The Energy Expo**
Miami Airport Convention Center (MACC) – Miami, FL; www.theenergyexpo.com

FEBRUARY 2019

- 27-28 **GLOBE Capital 2019**
Four Seasons – Toronto, ON; www.globeseries.com

MAY 2019

- 20-23 **AWEA WINDPOWER 2019 Conference & Exhibition**
Houston, TX; www.awea.org

SEPTEMBER 2019

- 23-26 **Solar Power International 2019**
Salt Lake City, UT; www.solarpowerinternational.com

Page	Company	Website
54	Abaris Training	www.abaris.com
11	ABB Group	tnb.com/tbsolar
25	Allearth Renewables	allearthrenewables.com
16	American Earth Anchors	americaneearthanchors.com
61	AWEA	www.americanwindweek.org
12	AWT Suncon, LLC	www.awtsuncon.com
38	Axitec, LLC	www.axitecsolar.us
5	Baja Carports	www.bajacarports.com
17	Burndy	www.burndy.com
48	CAB Products	www.cabproducts.com
63	CANWEA	windenergyevent.ca
10	Continental Control Systems	www.ctlsys.com
33	Cotek Electronic Ind. Co. Ltd	www.cotek.ca
22	Crown Battery	www.crownbattery.com
52	CTC Global	www.ctcglobal.com
6	CyboEnergy	www.cyboenergy.com
34	Delta Electronics (Americas) Ltd.	www.delta-americas.com/solarinverters
19	Dynapower	www.dynapower.com/dc-dc
46	Eco Foundation	www.ecofoundationssystem.com
18	Eko Instruments (USA) Inc	www.eko-usa.com
69	Energy Storage International	energystorageinternational.com
66	Energy Storage North America	esnaexpo.com
OBC	Exxon	mobil.com/wind
20	Fall Protection Distributors	www.standingseamroofanchor.com
31	Fronius USA	www.fronius.com
9	GameChange Solar	gamechangesolar.com
3	Growatt USA Inc.	www.growatt-america.com
23	HuksefluxUSA Inc	www.huksefluxusa.com
23	Iso-Cal North America	www.isocalnorthamerica.com
46	KB Racking	www.kbracking.com
26	Kipp & Zonen	www.kippzonen.com/energy
50	M Bar C Construction	mbaronline.com
14	Mersen USA Newburyport-MA, LLC	ep.mersen.com
15	MK Battery	mkbattery.com
56	Morgan Advanced Materials	www.morganplc.com
65	Nel Hydrogen	www.nelhydrogen.com
44	Nine Fasteners	www.ninefasteners.com
53	Nordic Fiberglass	www.nordicfiberglass.com
55	Olympus America	www.olympus-ims.com
7	OMCO Solar	www.omcosolar.com
47	OMG Roofing Products	www.omgroofing.com
27	Panasonic	na.panasonic.com/us/solarpanels
29	PCL Construction Enterprises, Inc.	www.pcl.com
59	Phoenix Contact	www.phoenixcontact.com
24	Polar Racking	www.polarracking.com
IBC	Port of Stockton	portofstockton.com
13	Power Electronics	www.power-electronics.com
46	Preformed Line Products	www.preformed.com
51	Quick Mount PV	quickmountpv.com
43	RBI Solar	www.rbisolar.com
67	Rhombus Energy Solutions	www.rhombusenergy.com
49	Rolls Battery	rollsbattery.com
42	S-5	www.s-5.com
IFC	Shoals	www.shoals.com
37	Sinexcel	sinexcel.us
50	SMARTTECH	smartechonline.com
42	Solar Connections International	solarconnections.com
21	SolarRoofHook	www.solarroofhook.com
40	Sollega	www.sollega.com
39	Soltec	soltec.com
41	Staubli	www.staubli-alternative-energies.com
36	TMEIC	www.tmeic.com
58	Transportation Partners and Logistics LLC	tpandl.com
45	Trojan Battery	trojanbattery.com/gosolar
62	Wanhe Filtration	www.whfilter.com
57	WindEnergy Hamburg	windenergyhamburg.com
60	Worldwide Machinery	wrsrents.com

Send us your clean energy show and event listings.

Email information to the editor at editor@nacleenergy.com

THE PORT OF STOCKTON YOUR PERFECT PIVOT POINT



We stay in constant motion so that your wind energy components reach the market on time and ready to spin. We give you 24/7 access to your cargo, on-dock rail facilities, and we are adjacent to less congested highways. This makes our turn-around time second to none. Need space to prepare your cargo for the next leg of the journey? We have ample lay-down area and two mobile cranes to handle over-size and heavy lift cargo.

The Port of Stockton: we keep things moving at a key turning point in your supply chain.



Port of Stockton
CALIFORNIA

209 • 946 • 0246
PORTOFSTOCKTON.COM

The best view you don't need to see

Backed by a seven-year warranty that requires no top-treating service, Mobil SHC™ Gear 320 WT synthetic wind turbine oil is formulated for lasting performance to help minimize maintenance and enhance productivity. Approved by many leading equipment builders. Learn more at mobil.com/wind

Energy lives here™

Mobil SHC™

Performance by ExxonMobil